

The Original

**I.S.T. Molchtechnik GmbH**  
The address for  
pigging technology

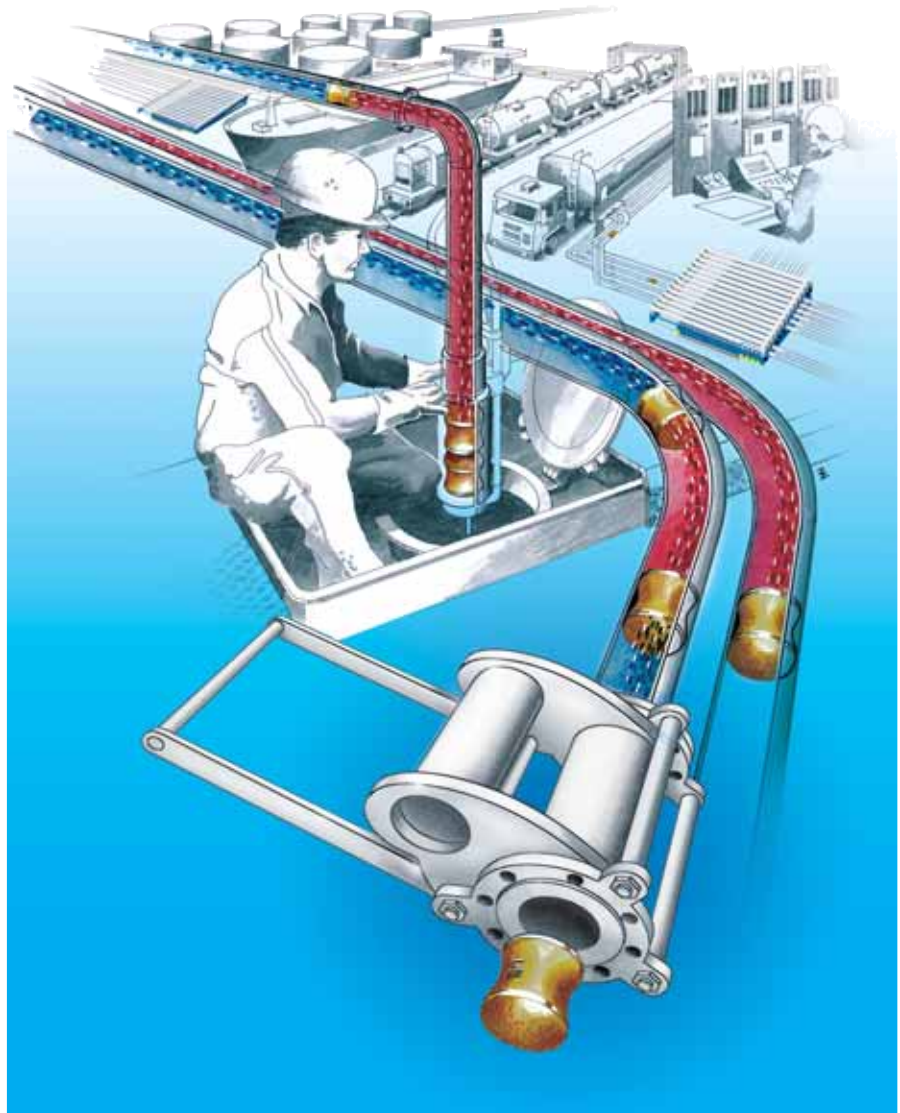

Experience in pigging technology for more than **35** years

## The idea of pigging

**Pigging technology is the most cost effective and environmentally friendly method of simultaneous product handling and pipework cleaning. This technology can be applied in almost all types of industry.**

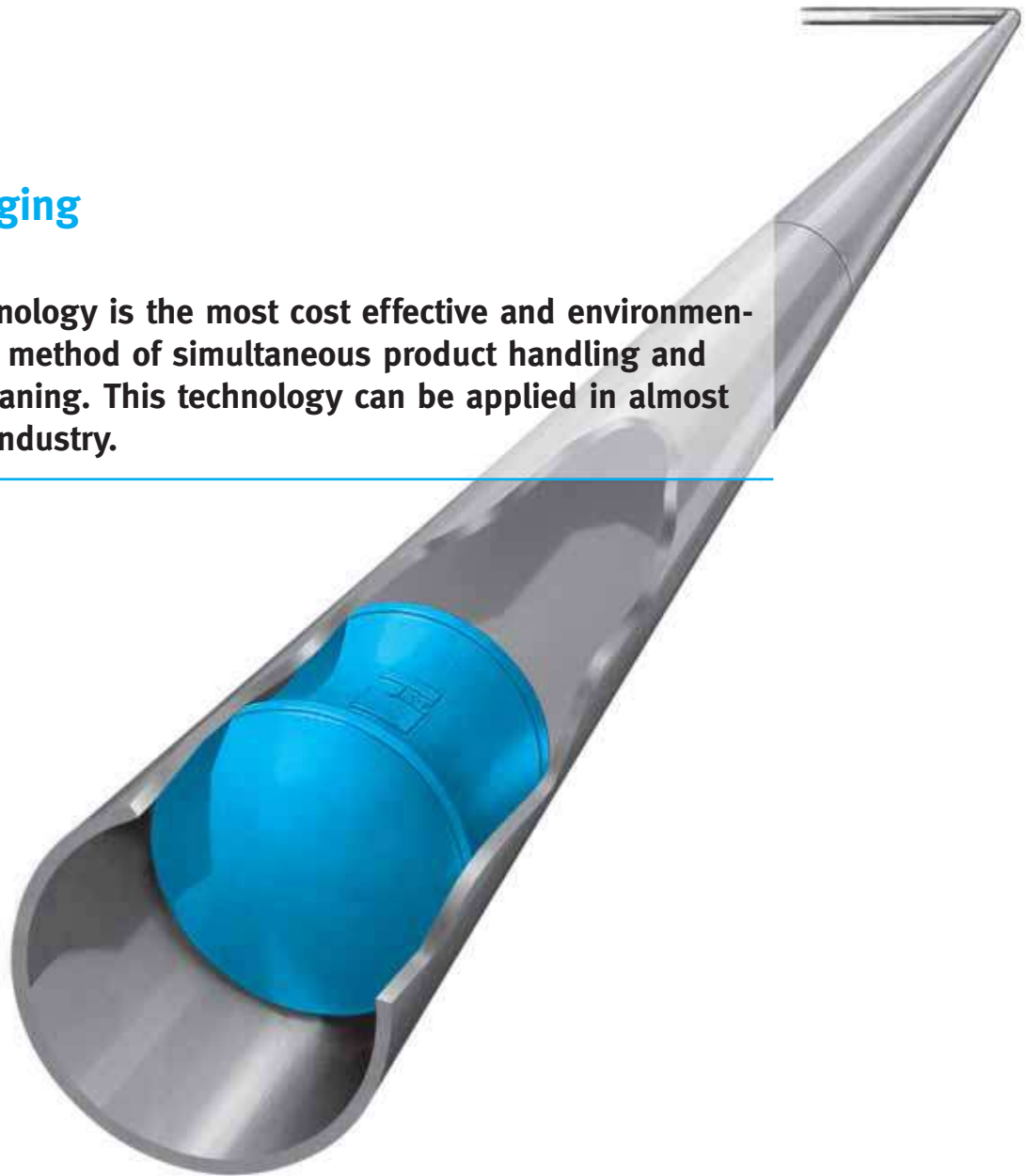

The pipeline contents is recovered by a special contoured plug, the "pig", which is driven by a propellant. This method of batch separation is used in many industries on a wide variety of products. All I.S.T. pigs and stations are manufactured to the highest possible standards in order to ensure that optimum pigging results are always achieved.

This catalogue provides outline details for all I.S.T. components and should enable you to plan the initial configuration of the proposed pigging system. However, for

detailed system design and planning we recommend that you seek further advice from I.S.T.'s qualified project engineers and benefit from their many years experience in this specialised field.

We endeavour to provide a very high level of customer care and after sales service to all our clients. With this in mind we recommend that I.S.T. service engineers are utilised for start-up, commissioning and training works. This will ensure that the pigging system is installed correctly and operates to your entire satisfaction.

## Description of a typical pig cleared process flow system.

This flow scheme gives an overview of how the range of equipment in the catalogue could be connected together at a "typical" plant installation.

The pig loading and unloading stations (T 29 & T 39) are positioned at the pig launching stations. Tee-pieces (T 10), Tee-sleeve valves (T 01), Tee-ring valves (T 09), Three-way valves and different manifolds interconnect the product inlet points with the piggable distribution system.

The discharge of the products can then take place through barrel filling valves (T 50), Tee-ring valves, Three-way valves, Tee-pieces and Loading arms (T 91) with a piggable filling head (T 02). Individually, all these units can also be used as Pig launching and receiving stations.

The choice of the correct piece of piggable equipment depends on several factors. Examples of this are the characteristics of the products to be transferred, plus the required cleanliness / minimal contamination aspects of the finished pipework. Experienced engineers from I.S.T. are available with advice as required. This will ensure that the optimum selection of equipment, on both a cost and suitability basis for your application, is chosen.

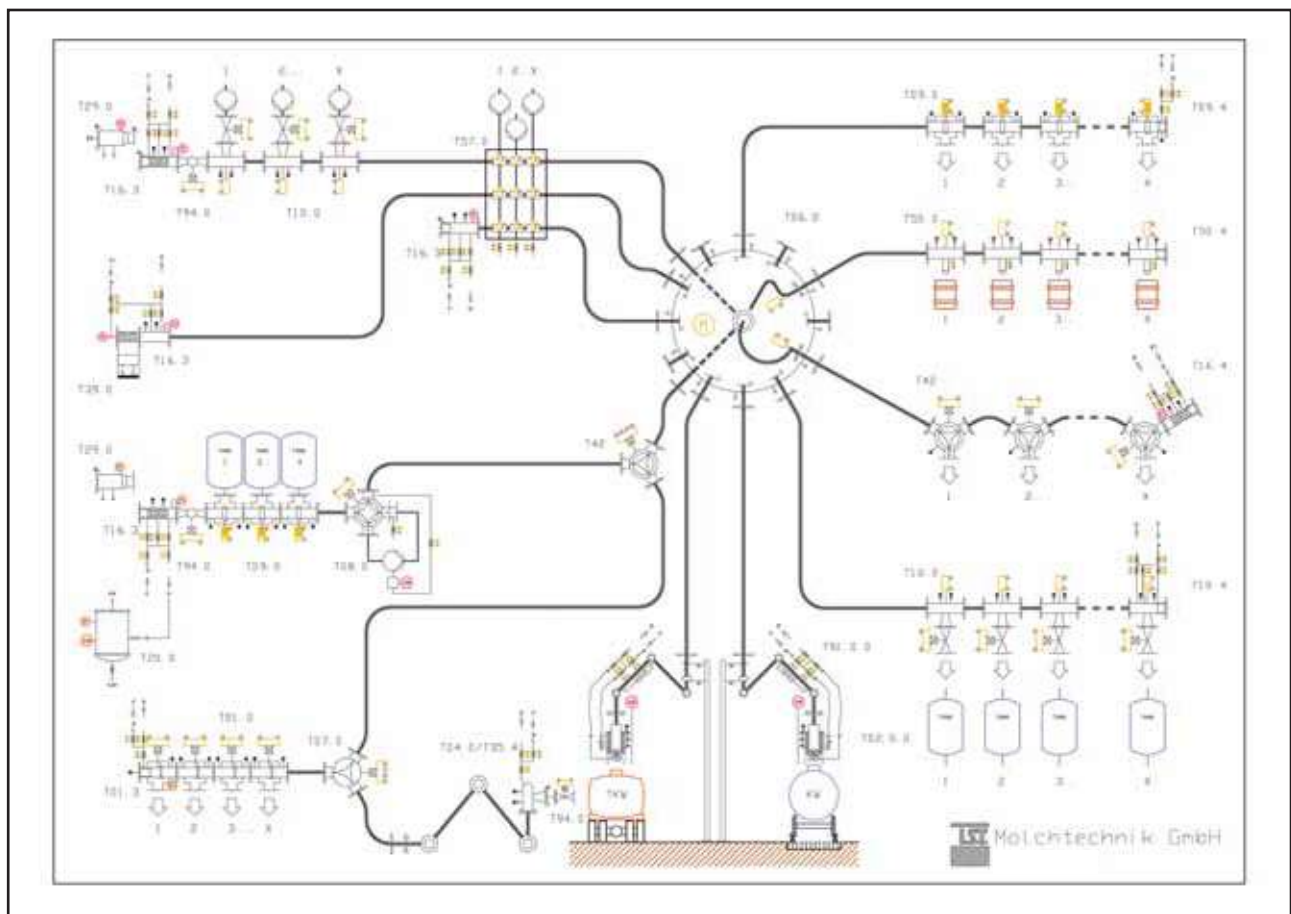

## I.S.T. Headquarters, Hamburg



## I.S.T. provides the following services:

- ▶ **Planning and conception of complete systems**
- ▶ **Retrofitting and modification of existing systems**
- ▶ **Piggable stations and manifold systems**
- ▶ **Pipework**
- ▶ **Control systems**
- ▶ **Accessories**
- ▶ **Technical support**
- ▶ **After sales service - commissioning, training, etc.**

I.S.T. manufactures a wide range of both welded and cast stations, providing a very flexible product range.

- Welded stations can be manufactured according to individual customer requirement.
- Cast stations are available in many different designs to suit various functions. All stations are proven designs and provide reliable operation and long service life for all parts (incl. seals).

### Technical data for standard product range:

Available diameters:	DN 25 / 1" up to DN 350 / 14"
Flanges:	DIN or ANSI
Pressure:	PN 16 / 150 lbs (other pressure stages on request)
Temperature:	up to 80°C (higher temperatures on request)
Materials:	carbon steel and stainless steel
Seals:	NBR, FKM, PTFE, AU, VMQ, EPDM (other materials on request)

In this catalogue you will find a résumé of all stations, pigs, accessories and services available at I.S.T.

## Contents

Product group	Type no.	Description	Page
Station, T-Form	01	T-Sleeve valve	AT 1
Station, T-Form	09	T-Ring valve	AT 1
Station, T-Form	10	T-piece	AT 2
Station, T-Form	10.3/4	T-piece as pig launching and receiving station	AT 2
Station, T-Form	26	Filter with pig launching and receiving station	AT 2
Station, T-Form	35	Pig launching and receiving station with 90° branch	AT 3
Station, T-Form	40	T-Port valve	AT 3
Station, T-Form	40.29	T-Port valve as pig launching and receiving station	AT 4
Station, T-Form	43	Inline valve	AT 4
Filling station	02	Loading lance for tank trucks and tank wagons	AB 1
Filling station	50	Loading arm	AB 1
Filling station	91	Loading valve	AB 1
Station, straight form	14	Pig receiving station with pig catcher ring	AG 1
Station, straight form	16	Pig launching and receiving station	AG 1
Station, straight form	17	Pig trap	AG 1
Station, straight form	29	Pig loading and unloading station	AG 2
Station, straight form	39	Pig loading and unloading station, swivel type	AG 2
Three way valve	41	Three way valve, cylinder	AW 1
Three way valve	42	Three way valve, ball	AW 1
Manifold	06	Rotary manifolds 1 to 6 - 2 to 12	VT 1
Manifold	06	Plug in manifolds	VT 1
Manifold	08	2/2 way manifolds	VT 2
Manifold	51	1 to 4 manifold	VT 2
Manifold	57	Full system manifold	VT 3
Pigs	19	DUO-pig	M 1
Pigs	19	DUO-Lip pig	M 1
Pigs	19	DUO-Lip pig with replaceable lips	M 2
Pigs	19	Jet pig	M 2
Pigs	19	Special pigs	M 2
Connecting element	99	Product hose	VE 1
Connecting element	04	Swivel arm	VE 1
Components	45	Inline Blender	C 1
Components	45	SMB Simultaneous Metering Blender	C 2
Components	65	DDU Drum Decanting Unit	C 3
Accessories	20	Pressure relief vessel	Z 1
Accessories	27	Sliding coupling	Z 1
Accessories	31	Pig sensor/Manual pig locator	Z 2
Accessories	32	Pig stop/Pig retainer	Z 3
Accessories	33	Swivel joint	Z 3
Accessories	34	Welding rings	Z 3
Accessories	48	Control units	Z 4
Accessories	59	Pipeline and pipe bends	Z 4
Accessories	92	Measuring instruments	Z 5
Accessories	97	Air pressure booster	Z 5
Service		Engineering	S 1
Service		Site supervision service	S 1
Service		Test pigging	S 1
Service		Training	S 2
Service		Repair and maintenance	S 2
Service		Technical support	S 2

## T-shape (incl. pig launching and receiving stations)

### T-sleeve valve T 01

The T-sleeve valve is a highly versatile station. It serves as a piggable T-piece, an interlock device and as a pig launching and receiving station. This patented valve is available both as manual (with hand lever) and automatic version (with actuator).

The T-branch can be locked with a sliding sleeve and the straight passage can be pigged pocket-free. The sliding sleeve is simple in operation because it is 100% relieved from pressure. Moreover, its sealings have a long service life. The T-sleeve valve functions as a pig launching and receiving station when a pig stop insert is installed. This station can be equipped with contamination control and other accessories (Pig locators, pig sensors, pressure relief etc.)

Available diameters: DN 80 - DN 100 (3" - 4")

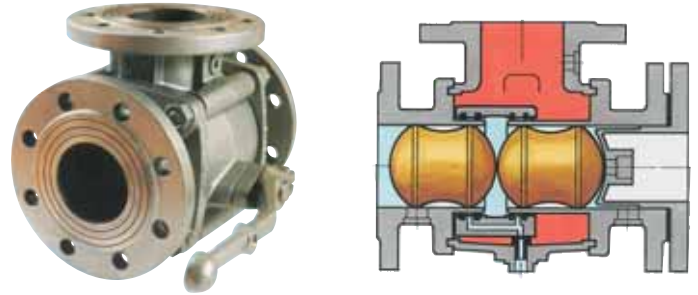

### T-ring valve T 09

The T-ring valve has three functions: Piggable Tee piece, product isolation valve and pig stop. It is possible to use it as a single station or as a part of a manifold assembly. The T-ring valve is operated automatically. Its straight passage can be pigged pocket free when the valve is closed. The T-branch is opened by the sliding ring that also serves as pig catcher. Moreover, contamination is avoided by a spring-balanced seal design.

Available diameters: DN 25 - DN 150 (1" - 6")

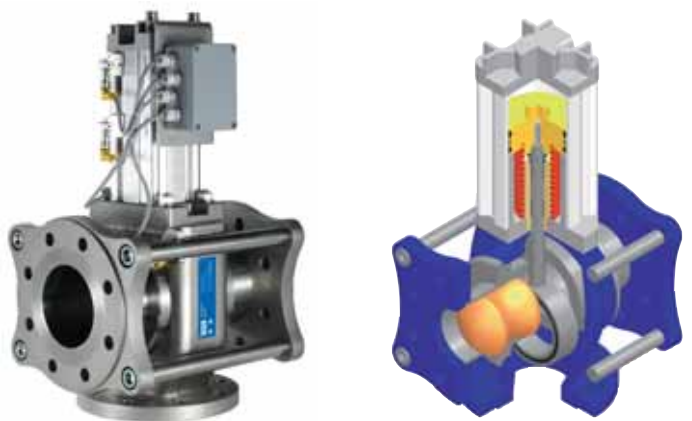

## T-shape (incl. pig launching and receiving stations)

### T-piece T 10

The T-piece is piggable in the straight passage. During the pigging process the special T-branch is completely sealed by the lips of the pig. The station can also be equipped with a pig stop that serves as a buffer for one and two pig systems. The T-piece is a welded station, especially suitable for non standard designs, inner diameters, heating jackets etc.

Available diameters: DN 25 - DN 350 (1" - 14")

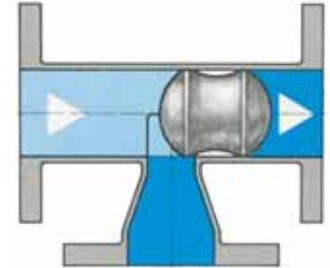

### T-piece as pig launching and receiving station T 10.3

This pig station is applicable for one and two pig systems. It can be operated both manually or automatically. It is equipped with a pig stop insert that catches the pig. This insert can be removed for pig change. Sockets for propellant as well as electrical and manual pig sensing can be installed individually. In order to avoid the pig being pulled out of its position due to product turbulences a pig retainer can be mounted.

Available diameters: DN 25 - DN 350 (1"-14")

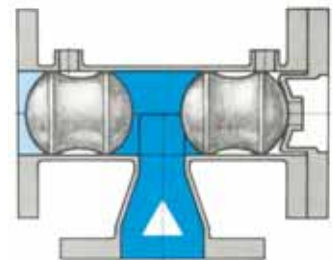

### Filter with pig launching and receiving station T 26

This station combines the functions of a filter, a piggable T-piece and a pig launching and receiving station. Pigging is possible up to the filter insert. The filter is a reversible-flow filter that can be changed quickly. Moreover, it is available in various mesh sizes.

Available diameters: DN 80 - DN 100 (3" - 4")

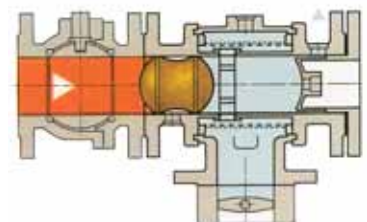



## T-shape (incl. pig launching and receiving stations)

### Pig launching and receiving station T 35 with 90° branch

In principle, this station has the same function as the T 10.3. The difference is that the T 35 has no removable pig stop insert and therefore the station cannot be opened. This has the effect that pockets for contaminate and bacteria are reduced and the station has a relatively low weight. This station is often used for hose connections where an unloading of the pig is not necessary.

Available diameters: DN 25 - DN 350 (1" - 14")

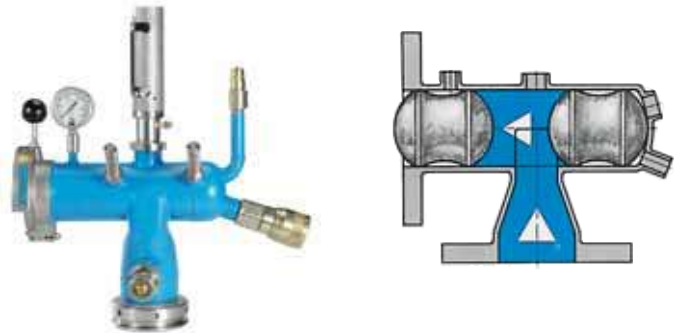

### T-Port Valve T 40

The T-Port valve is particularly suitable for single direction pigging systems. For such applications the T-Port valve provides safe and clean pigging results comparable with two pig systems, but with reduced control system expenditure: with only two positions it is possible to open the T-Branch and transfer the product with minimal pressure drop and also stop the pig. In this position the pipe behind the T-Port valve is isolated. In the second position the pig passage is opened and the T-Branch is isolated.

The sealing principle utilised in the T-Port valve is the same as our proven T 41 Three way valve. The main seal is manufactured from PTFE and covers the valve drum completely. Hence, no product residue remains in the piggable passage.

Available diameters: DN 25 - DN 300 (1" - 12")

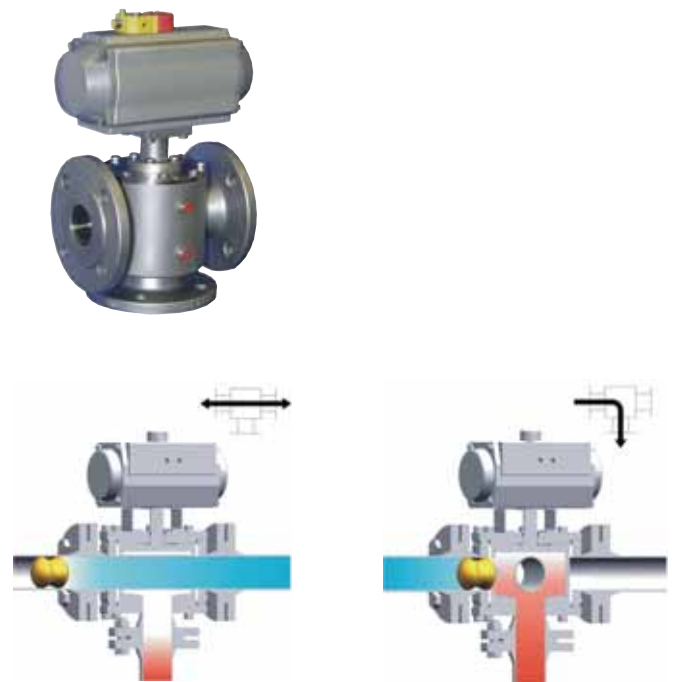

## T-shape (incl. pig launching and receiving stations)

### T-Port valve as pig launching and receiving station T 40.29

T-Port valve as launching station: New safety standards for pig changing procedure incorporating the many advantages of the multifunctional T-Port valve, together with a unique and innovative safe method for loading and unloading pigs. This version is also equipped with an integrated pig changing chamber and pig propellant connections. In addition to the standard two automated valve positions there is also a third manual valve position for changing pigs. The pig changing procedure requires no external utility services, or control system action. The orientation of the pig changing chamber ensures that the pigging line is isolated when changing pigs, providing the highest levels of operator safety.

Available diameters: DN 25 - DN 300 (1" - 12")

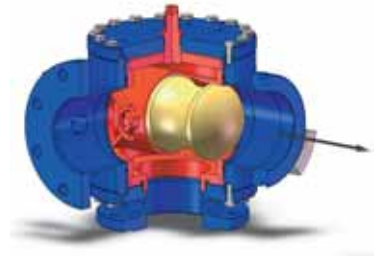

### Inline valve T 43

The Inline valve T 43 can dose single product components into the piggable line. The flow in the branch is controlled by a piston. In the closed position the piston closes exactly with the pipe's inner wall and thus grants a pocket free passage for the pig. The inline valve has a double acting pneumatic actuator with spring return so that in case of emergency an immediate closing of the station is made sure. The non-piggable branch can easily be cleaned by special rinsing connections.

Available diameters: DN 25 - DN 100 (1" - 4")

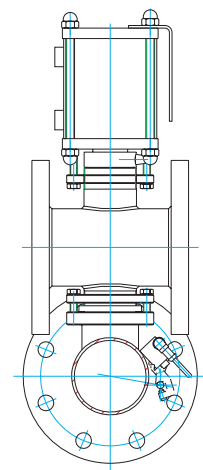

## Straight shape

### Loading lance T 02

The loading lance is designed for application in piggable filling plants. It is mounted at the end of a loading arm and allows pipeline pigging through the complete loading arm. The pig can transport the product into the loading lance or back into the initial source tank.

The loading lance is equipped with a level control switch. Thus the product is transported back to the tank after loading and overfilling of tank trucks or wagons etc. is avoided. Due to the fact that the loading arm is fully piggable, it is possible to fill several different products through the same loading arm. Product flow is controlled by a sliding sleeve installed in the loading lance. This sleeve is operated by instrument air (positions open/closed/throttle). In case of emergency air failure, the loading lance is closed automatically by spring.

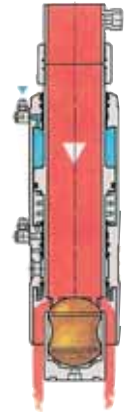

Available diameters: DN 50 - DN 100 (2" - 4")

### Loading valve T 50

The loading valve is designed for filling of drums and other containers with a bunghole > 60 mm. The pig pushes the product directly into the filling station. Thus the contents of the non-piggable area is fully drained. The loading valve can handle various filling operations such as top level, bottom level and bottom bunghole filling. This valve design allows a fully automated piggable filling plant to be realised.

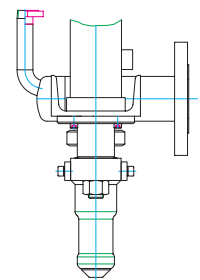

Available diameters: DN 50 - DN 100 (2" - 4")

### Loading arm T 91

With the loading arm T 91 pigging through the arm into the filling valve is possible. It has large positioning possibilities that can be adapted individually. Special constructions for top level and bottom level filling are possible, as well as a suction device for the filling process. The loading arms are available with mechanical or pneumatic level compensation.

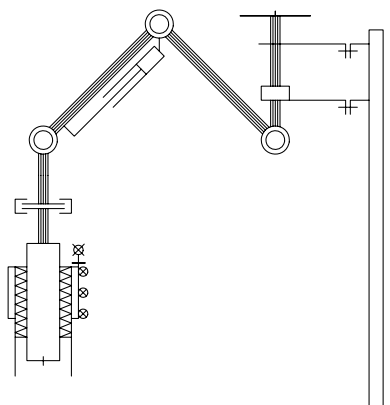

Available diameters: DN 50 - DN 100 (2" - 4")

## Straight shape

### Pig launching and receiving station T 14

The product can flow straight through this station whilst the pig is held by the internal pig stop ring. It can be applied to both one and two pig systems. In order to rinse the pig the station can be equipped with internal and external by-passes. Thus, it is possible to clean the pig as well as the non piggable area. After the filling and cleaning process the pig is propelled back into the launching station.



Available diameters: DN 25 - DN 350 (2" - 14")

### Pig launching and receiving station T 16

This station can also be applied to both one and two pig systems. It is equipped with a pig stop insert and facilitates rinsing and drying of the pigs after the pigging process by installation of internal and external by-passes. With help of the I.S.T. sliding coupling it is easy to connect the T 16 to the pig loading and unloading station T 29.

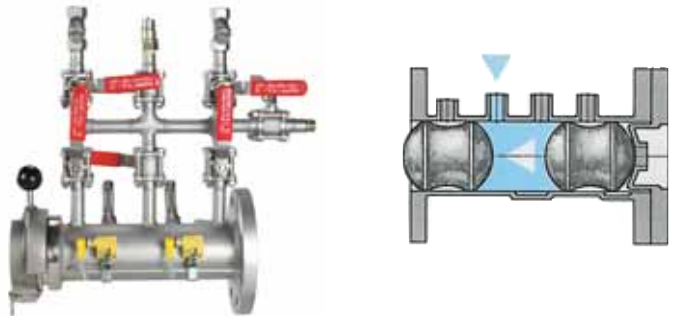

Available diameters: DN 25 - DN 350 (2" - 14")

### Pig trap T 17

The pig trap facilitates the catching of the pig within the pipeline. With this simple station the pig can be stopped at any desired position. Thus, it is also possible to pig only parts of the pipeline. It can be applied to both one and two pig systems. It can be operated manually (had lever), or automatically.

Available diameters: DN 25 - DN 300 (2" - 12")

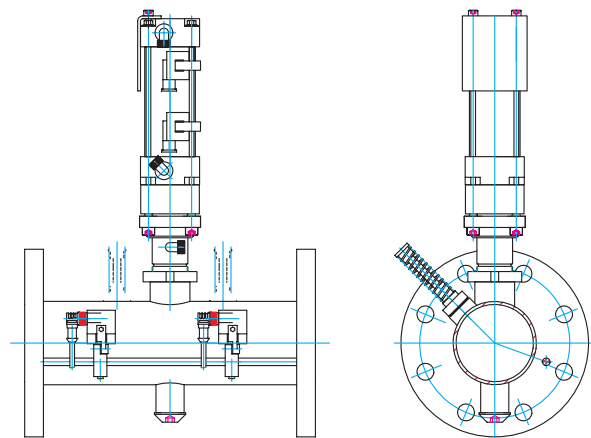

## Pig loading and unloading stations

### Pig loading and unloading station T 29

With this station pigs can be safely removed from or loaded into the system. On the loading/unloading side it is equipped with I.S.T. sliding couplings (male and female part) which facilitates a quick and safe unloading. After opening, the pig can easily be removed from the oversize section of the station. In order to avoid an unauthorised opening of the station it can be locked mechanically or pneumatically. The pipeline side can be equipped either with a flange or a female sliding coupling. Due to safety reasons I.S.T. recommends the use of this station.

Available diameters: DN 25 - DN 350 (2" - 14")

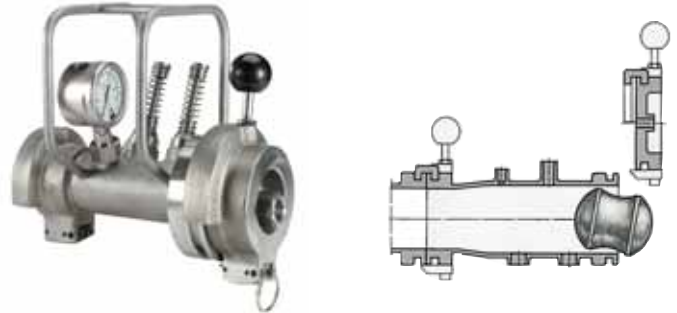

### Pig loading and unloading station T 39

With this station the loading and unloading of the pig from a pipe system is also easy, fast and safe. A part of the station can be swivelled out of the pipeline. Thus, a pressure free loading or unloading of the pig is secured. So the process of pig exchange is made easier and operational errors are avoided.

The pipeline side can be equipped either with a flange or a female sliding coupling. Due to safety reasons I.S.T. recommends the use of this station.

Available diameters: DN 25 - DN 150 (2" - 6")

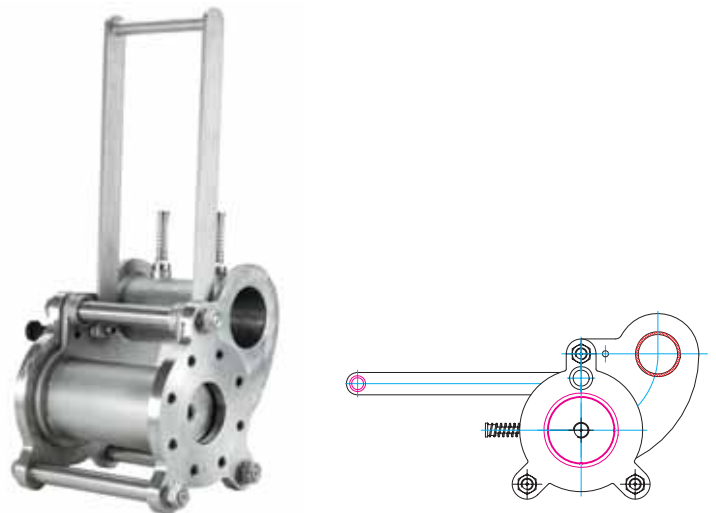

## Three way valves

### Three way valve T 41 (cylinder)

This three way valve allows either two or three pipeline routes to be connected. The internal cylinder rotates and locks the desired connection. Due to its shape the valve is almost pocket free and is therefore successfully used in the chemical and in the paint industry. The T 41 can be operated manually (hand lever) or automatically. In combination with a pig stop insert and a pig sensor the T 41 can also be used for launching and receiving of a pig. Thus the pig can be deviated into another pipeline or driven back into its home station.

Available diameters: DN 50 - DN 300 (2" - 12")

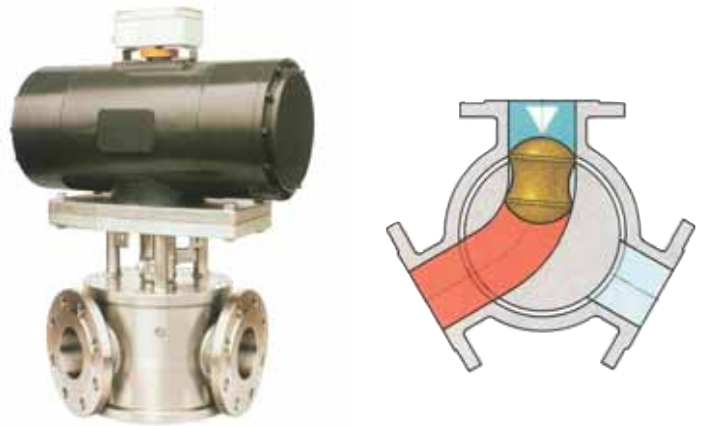

### Three way valve T 42

The three way valve T 42 has the same switching functions as the T 41. Optimum pigging results are provided thanks to the big radius in the passage. Due to the small torque switching of the valve is made easier. The T 42 can be operated with a lever or by a pneumatic actuator for two or three positions. In combination with a pig stop insert and a pig sensor the T 42 can also be used for launching and receiving of a pig. Thus, the pig can be reversed into another pipeline or driven back into its home station.

Available diameters: DN 50 - DN 100 (2" - 4")

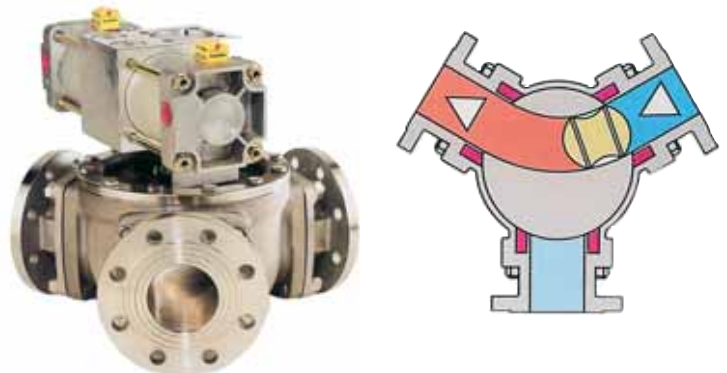

## Distribution / Manifolds

### Rotary manifold T 06

The I.S.T. rotary manifold T 06 connects one or two supplies with up to 18 outlets. Thus, tank groups, mixers etc, can be interconnected to 1 or 2 filling devices. The fully piggable version of the T 06 allows for a pigging process from the tank up to the filling device. The manifold is also available with dry break couplings. These couplings shut both sides of the line after disconnection of the couplings.

The I.S.T. rotary manifolds are available in the following designs:

Connection	Version
1 to 6	manual
1 or 2 to 12, 1 to 18	manual / automatic

Available diameters: DN 50 - DN 150 (2" - 6")

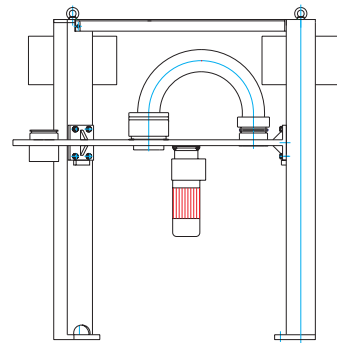

### I.S.T. plug in manifolds

Plug-in manifold concept, using piggable elbows to connect pipelines. The connections are made by the patented I.S.T. sliding coupling - uniquely safe and comfortable to operate

Available diameters: DN 50 - DN 100 (2" - 4")

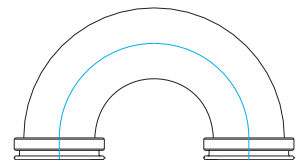

## Distribution / Manifolds

### Two / two way valve T 08

This valve facilitates the simultaneous diversion of product flows in two directions. Thus, different pipelines can be switched and pigged. The manifold can also be used as a piggable pump bypass. In this case the product flow is connected to the pump. After conveying the piggable pump bypass is switched on. Its integrated cylinder is pocket free due to its optimum sealing and therefore it can especially be used for products that allow no or only minimum contamination. The valve can be switched either manually or automatically. There is no overlapping while switching since all outlets are blocked. In combination with a pig stop insert and a pig sensor the T 08 can also be used for launching and receiving of a pig. Thus, the pig can be reversed into another pipeline.

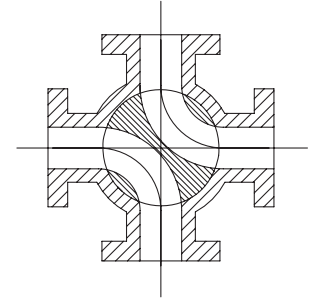

Available diameters: DN 50 - DN 125 (2" - 5")

### 1 to 4 manifold T 51

This manifold is suitable for smaller distributions. 4 supplies which are arranged radially can be connected to a central outlet. Thus an easy and cost effective distribution is facilitated. This manifold is based on the sealing principle of the T 41 (cylindrical form). Due to the fully piggable and pocket free design the possibility of contamination is almost deleted. A pneumatic four position actuator rotates the valve to any of the desired connections.

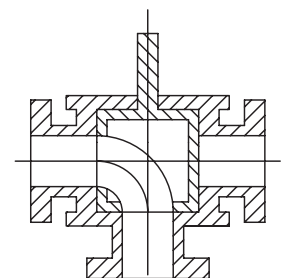
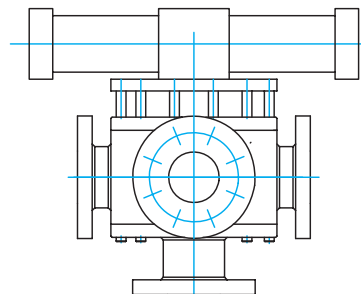

Available diameters: DN 50 - DN 125 (2" - 5")



## Distribution / Manifolds

### I.S.T. Full system manifold T 57

This is the first manifold which allows pipelines of different nominal diameters to be combined in a single design (DN 50, 80 and 100). The system is closed and piggable on one side. The full system section consists of non-piggable rectangular ducts for product feed. At right angles to these ducts are the piggable pipelines which are connected at the intersection by means of a ring valve principle. This ring valve opens the connection from the product feed duct to the piggable part of the manifold and simultaneously acts as a pig receiving station. The respective ring valves are opened by a manual or pneumatic actuating unit. This actuating unit moves in parallel direction over the piggable pipeline to the required product feed full system section. This means that only one actuating unit per piggable pipeline is required. Cost effective software and interlocking devices are thus reduced to a minimum. The small shut-off unit makes the manifold very compact. All dynamic seals are exchangeable within minutes. The T 57 makes it possible to connect and distribute up to 50 feed pipelines to as many as 20 pigging pipelines in a single module. All filling and pigging processes are effected parallelly. The manifold can open and close the connections independently. Transfer pumping from tank to tank or of pigging line into pigging line is also possible with the corresponding switch processes. This unique manifold design provides a very compact and low cost solution with minimal maintenance.

Available diameters: DN 50 - DN 100 (2" - 4")  
others on request

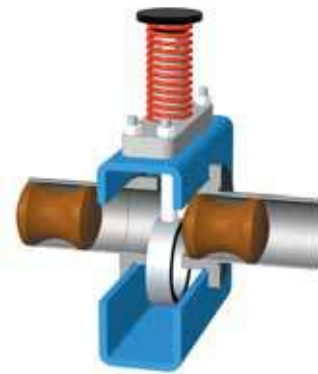

## Pigs

I.S.T. has more than 35 years experience in design and development of pigs for pipeline cleaning. I.S.T. pigs are manufactured in various designs and materials to suit individual customer requirements. In principle, if a product can be pumped then it can also be pigged: Lube oils, aggressive chemicals, toiletries, cosmetics, pastes and foodstuffs. In special cases even granulates, powders etc., can also be pigged. We have outlined below the various pig designs available from I.S.T.



### I.S.T. Duo-pig

The I.S.T. Duo-pig is used universally due to its form and the wide variety of elastomers it can be made from (AU, FKM, EPDM, NBR etc.). It is robust and simple to handle. Without having to take it out of the pipeline it can be rinsed in the pigging stations. The pig can be detected in the stations or in the pipeline due to its integrated magnet. For manual systems the Duo-pig can also be supplied without magnet. In this case it would be detected with manual pig locators.

Available diameters: DN 25 - DN 150 (2" - 6")  
On request also up to DN 300 (12")



### I.S.T. Duo lip pig

Due to its flexible sealing lips the I.S.T. Duo lip pig facilitates an optimum sealing. Even with inferior quality pipelines it provides excellent operation characteristics. It is also available with or without magnet. The body of this pig is manufactured from polyurethane (AU) - foamed or solid and the seal lips are non-abrasive solid polyurethane

Available diameters: DN 50 - DN 350 (2" - 14")



## Pigs

### I.S.T. Duo lip pig with replaceable lips

The I.S.T. Duo lip pig with replaceable lips is a special type of Duo lip pig that was designed especially for handling aggressive media. The advantage of this pig is that the seal lips can be replaced separately. The body of this pig is manufactured from a chemical resistant thermoplast such as PA 6 or PVDF. The replaceable sealing lips are typically manufactured from non-abrasive polyurethane or FKM (Viton). In most cases the Duo lip pig with exchangeable lips is applied with integrated magnet.

Available diameters: DN 50 - DN 300 (2" - 12")



### I.S.T. jet pig

The I.S.T. jet pig is used for pigging granulates and powders. Used regularly it prevents the formation of residual material. It can be manufactured in various elastomers such as: AU, FKM, EPDM, NBR etc. and can therefore be used universally. The jet pig is available with or without integrated magnet.

Available diameters: DN 25 - DN 150 (2" - 6")  
On request also up to DN 300 (12")



### I.S.T. special pigs

In addition to the above pigs I.S.T. also designs pigs for special applications. These special types (e. g. brush pigs, pigs with more sealing lips or pig forms designed for systems that outside our standard product range)

Available diameters: on request



I.S.T. pigs are sold together with our pigging systems, only.

## Connecting elements

### Piggable hoses T 99

Piggable hoses are available in different materials for different products as lube oils, chemicals, food etc. The professional mounting of the steel/stainless steel parts as coupling flanges or swivel joints grant highest flexibility and safety. Examples for the use of piggable hoses are distributions with different connecting points and changing distances as well as the flexible filling into tank trucks etc.

Available diameters: DN 50 - DN 100 (2" - 4")

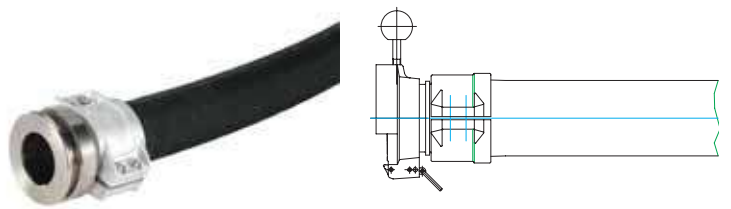

### Swivel arm T 04

With the I.S.T. swivel arm variable piggable connections can be produced. With the corresponding coupling connections between pipeline connections and tank trucks or movable tanks etc. are possible.

Available diameters: DN 50 - DN 100 (2" - 4")



## Components

### Inline Blender T 45

This continuous, dynamic multicomponent blender was designed for the continuous flow of 2-9 components. In the standard version it is possible to achieve a flow rate of 60 m<sup>3</sup>/h with a blending chamber volume of 60 l. Its special construction allows the direct mounting of regular stations. So a simultaneous supply of all components is possible. The locking cones of the regular stations open into the interior of the blending chamber and terminate with the interior side of the mixer. Control of the volume of the various mixing products is usually done through flow meters with pulse transmitters in connection with pneumatically operated control valves. The blending proportions are done through the control unit. The combination of I.S.T. Inline Blender and automatic control guarantees an accurate and consistent mixing result. Despite the varied flowpath of the components in the blending chamber the quality of the final blend is unaffected. Even products with very high and very low viscosity can be mixed together to a homogeneous product. Although the mixing time in the blender is relatively short, the mixed product is to exact specification from beginning to end of the operation. The liquid/liquid blending operation of the I.S.T. Inline Blender is an answer to the requirement of continuous process operation which is easier controlled and automated than conventional batch blending operation.

The excellent blending results show the effect of this unique technique.

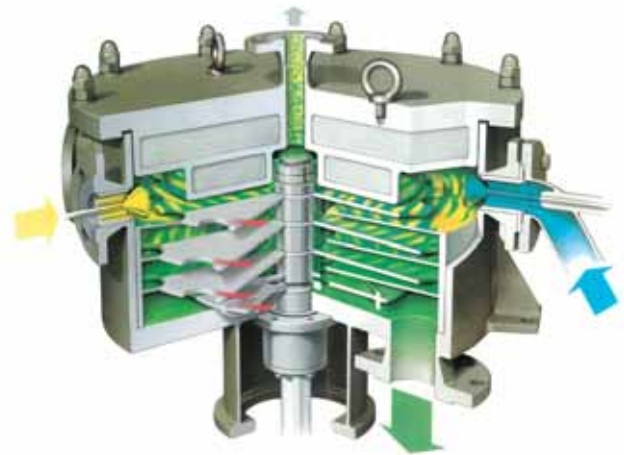

## Components

### SMB Simultaneous Metering Blender T 45

All raw material components (base oils and additives) are pumped to the SMB from dedicated tanks, where a series of metering channels equipped with mass flow meter, control valve and non-return valve allow very accurate and simultaneous dosing of all blend recipe components. The SMB design incorporates a fully piggable distribution header pipe in order to avoid cross-contamination between blend recipes and to maximise product recovery. This unique piggable SMB concept even allows for the different family groups of lubricating oils to be blended in the SMB and hence maximises plant equipment utilisation.

The general principle of operation for the SMB is as follows: Operator provides production data (such as: product name / code, type, blend size, and tank destination etc) to SMB control system.

The SMB control system will then automatically dose all required raw material components according to the customers specific blend formulation (recipe), in following three stages: First stage is an initial dosing and transfer of base oil, followed by dosing and transfer of the main blend components base oils and additives, followed by a final dosing and transfer of the remaining base oil. This dosing sequence ensures optimum pigging results are achieved, with respect to cross-contamination between subsequent SMB blends.

The pigging system is directly integrated in the SMB. Thus the connecting pipelines and the basic isolation valves can be emptied without residues.

The non piggable areas such as flow meters / counters are emptied according to a programmed procedure and rinsed with base product. Now the system is completely emptied and the next process can be prepared.



## Components

### DDU Drum Decanting Unit T 65

A perfect supplement in pigging technology in order to provide safety and functionality when emptying drums and containers (IBC). Here, the pumped products are often used as additives for blending processes. The decanting process is semi automated. With a pre-heated base product the drums will be emptied almost completely. The product is decanted with a pneumatically driven lance which transports the product directly into the piggable transport line. The product will be conveyed directly to the storage tanks or into the subsequent blenders. The exact dosing of the product is effected by a weighing system that is connected to the central control unit of the DDU. A quick change-over from drum decanting to container decanting can be done with help of the flexibly designed roller conveyor. The system can be retooled for the decanting of a completely different kind of packaging within seconds.

The advantages:

- Complete discharge of high quality additives
- No product losses thanks to pigging technology
- No cross-contamination between drummed additives
- Local control system for automated filling processes
- Unique combination with pigging technology
- Products are transported directly into a piggable station.
- Traversable and piggable pipe connections to the pump.
- Minimised, non-piggable pump areas
- Piggable connection direct to blender or storage tank



## Accessories

### Pressure relief vessel T 20

The pressure relief vessel is used for the safe venting and filtering of pig propellant (compressed air, nitrogen etc) and collection of residual contaminate. The T20 is equipped with a demister that separates contaminates and pig propellant. The volume of the residual contaminate is monitored by a level control switch allowing it to be disposed off as required.

The pressure relief vessel is available with a volume of 60, 100 and 300 litres as well as with or without heating.

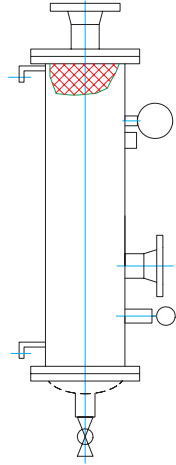

### I.S.T. Sliding coupling T 27

With the piggable I.S.T. sliding coupling the coupling of hoses or pipeline connections is made easier. Two coupling halves slide on each other until they are locked. Both coupling parts are sealed by an O-ring that lies in a special groove. The protected locking device grants a safe closure of the coupled halves.

The coupling system can be completed with a coding system. Thus each coupled connection can be monitored by a control unit so that operational errors are avoided

Available diameters: DN 25 - DN 100 (1" - 4")

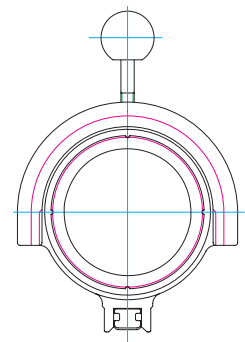



## Accessories

### Pig sensor, manual pig locator T 31

In order to locate the pigs in the pipeline or in the pigging stations I.S.T. has developed various special pig sensors. In automated systems the pig is equipped with an integrated magnet. The field of this magnet is sensed by a special magnetic field switch. For welded stainless steel stations these sensors are fixed to an externally mounted rod with a special clamp. This allows the sensor to detect the pig through the pipe wall. In cast stations other sensors are screwed into a housing. I.S.T. also offers electro mechanic devices for location of pigs without magnet.

For high temperature areas special sensors are also available.

All pig sensors are available for EX and NON-EX areas.

Pigging stations can also be equipped with manual pig locators. With this type of device a tappet is manually pressed into the station, in order to check for the presence of the pig. The tappet is then automatically removed from the pipeline by a spring.

I.S.T. also offers a portable pig sensor pen with which the pig can be detected throughout the pipeline. This method is only applicable for stainless steel pipelines.



electromagnetic



electromagnetic



electromechanic



mechanic

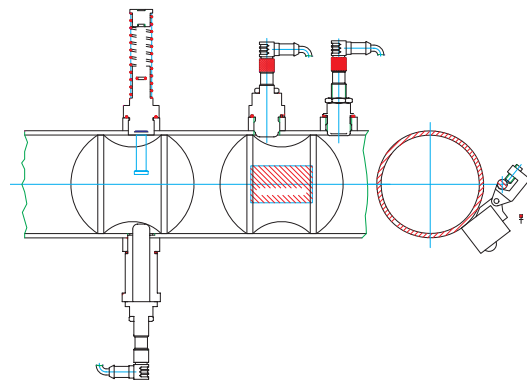

portable pig sensor pen

## Accessories

### Pig stop and pig retainer T 32

The pig stop catches the pig in the T-stations. So the pig can be used as a closure device.

The pig retainer is holding the pig in the launching or receiving station. It prevents the pig from being pulled out of its home position into the pipeline through high flow speed of the product.

The operation of the pig stop and the pig retainer can be done manually (with hand lever up to DN 100 / 4") or automatically (with actuator).

Available for diameters: DN 25 - DN 300 (2" - 12")

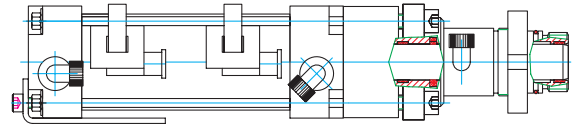

### Swivel joint T 33

The piggable swivel joint T 33 is a component that allows axial rotations into a piping system and thus facilitates a better flexibility. Swivel joints can make the handling of piggable hoses easier.

Available diameters: DN 50 - DN 150 (2" - 6")



### Welding ring T 34

Piggable pipelines have to be installed without any misalignment. A simple aid to assure correct alignment of a pipeline are welding rings. These rings provide an externally welded sleeve joint which prevents weld seams sagging into the piggable pipeline.

Available diameters: DN 50 - DN 250 (2" - 10")



## Accessories

### Control system T 48

Automated pigging systems need a control system for the control of the various steps of the pigging operation. This is effected by a "SPS" (stored program system). So the switch position of all stations and the position of the pigs can be controlled at any time. The elements of the pigging system can be connected to the control unit either conventionally or via a bus system. When programming the control system the knowledge of the programmers is most important in order to grant a smooth pigging process. I.S.T. has more than 35 years experience in development of automated process control.

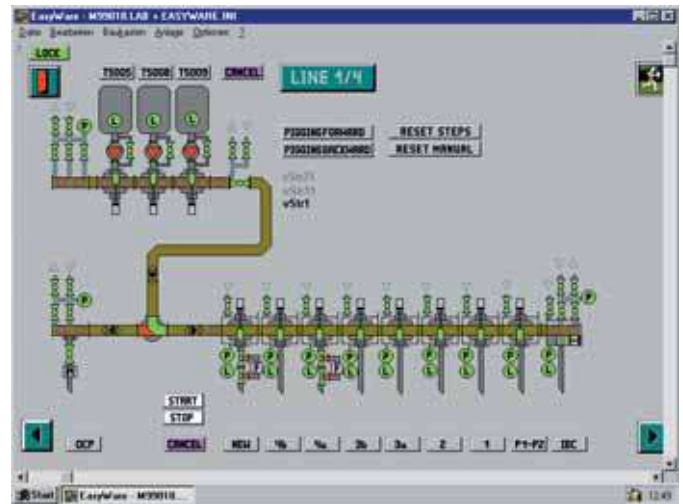

### Piggable pipes and elbows T 59

I.S.T. applies strict standards in view to the production of piggable pipes and elbows since the quality of these parts has a high influence on the pigging result. Pipe tolerances, ovality, surface quality, material thickness and the quality of the welded seams are the most important parameters. Piggable elbows are produced in a special method so that the roundness discrepancies are kept within small tolerances. For the different applications I.S.T. offers a wide range of pipes and elbows. Of course all parts are also available for the application in the chemical industry according to DIN 2430.

Available diameters: DN 25 - 300 (2" - 12")



## Accessories

### Measuring instruments T 92

For the control of pressure, filling level of liquids, volume flow etc. I.S.T. offers a wide range of various measuring instruments.



### Air pressure booster T 97

For all pneumatically actuated piggyback stations a certain compressed air supply is necessary. If this pressure is not available the air pressure booster can be used. This pump works with a pressure multiplication of 1 : 2 and is supplied completely with a pressure tank.



## I.S.T. Service

The supply of individual components alone will not guarantee the correct function of a pigging system. For optimum results it is very important to utilise the experienced engineering support and services which the I.S.T. service staff provides.

### Engineering

In the planning phase for a pigging system experience, co-operation and innovation are highly important factors for a successful end result. I.S.T. offers a complete planning and project engineering service for pigging systems from conception to final design, completion.



### Site supervision service

Experienced engineering support during installation, commissioning and final hand-over is a critical factor. We provide complete site supervision together with experienced partners.



### Test pigging

With test pigging new and existing lines are tested to confirm suitability for pigging. All pipe joints, elbows, welded seams are tested to identify any problem areas.

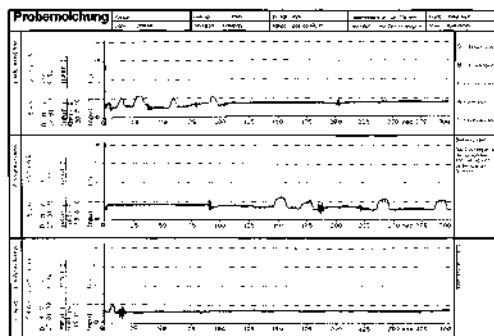

## I.S.T. Service

### Training

For the daily work with a pigging system detailed training of the operational staff is important. This kind of training is offered by I.S.T.



### Repair and maintenance

All I.S.T. pigging components are made from long wearing materials. However, certain maintenance work will obviously be necessary. For exchange of seals and further elements the experienced technicians are at your disposal; either for an exchange at I.S.T. in Hamburg or at your premises. Regular maintenance by I.S.T. personnel will ensure a continuous operation and avoids non-productive times. Should there, however, be any "emergency" the flexible I.S.T. team will always be at your disposal to solve any problems at site.



### Technical support

For any questions regarding pigging systems you can benefit from our technical support - by phone or personally. Be it for a planned or an existing pigging system, our experts will support you in word and deed.



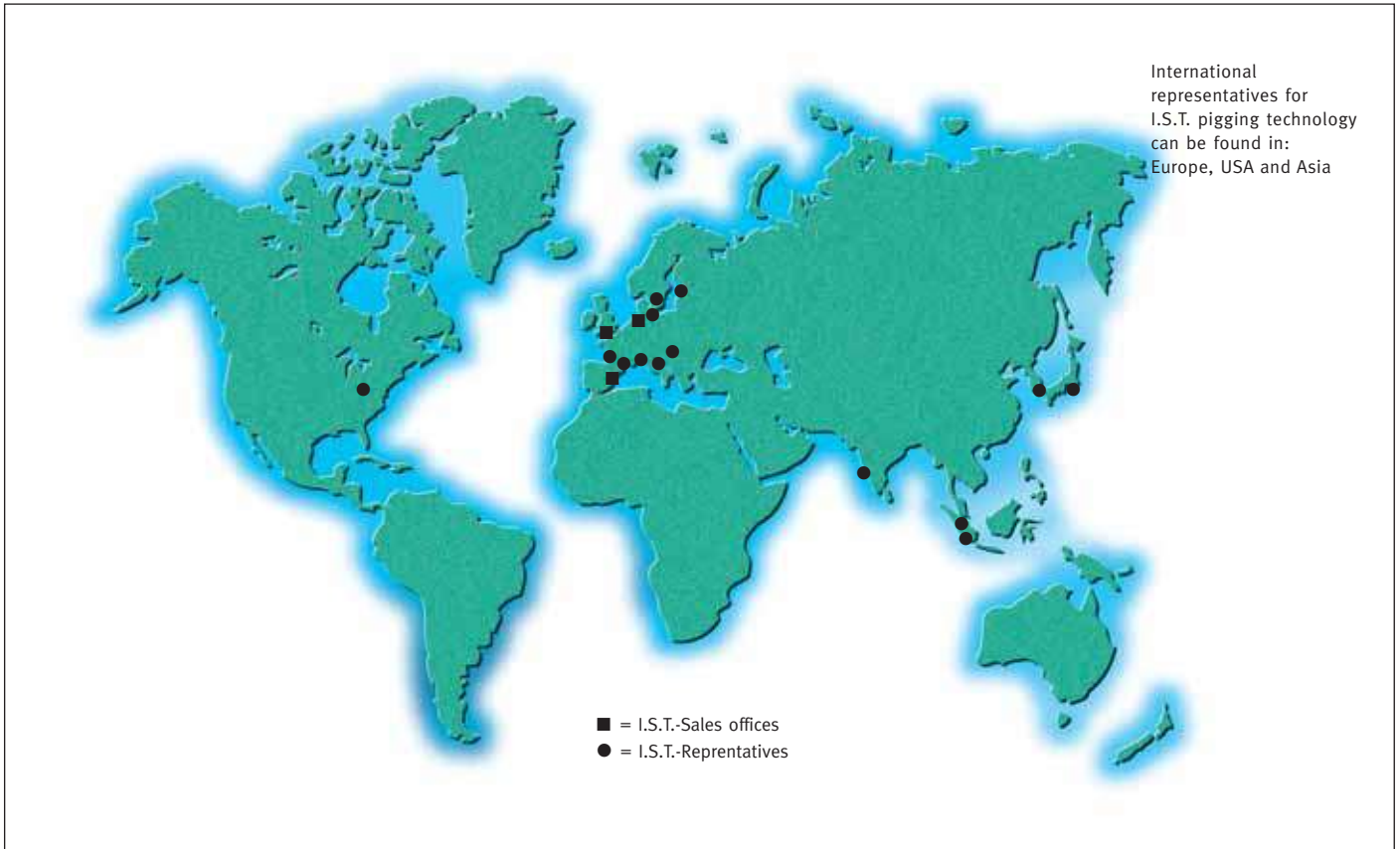

Whether you require partial retrofitting or a completely new system, I.S.T. pigging technology will suit your needs:

**System planning**

**Design**

**Partial and complete solutions,**

i.e. pigging fittings, pipe laying and control systems, pigging fittings and test pigging

**Installation**

**Maintenance**

**Inspection**

**Training**

... all from one supplier.



**I.S.T. Molchtechnik GmbH**

Schierenberg 74  
D-22145 Hamburg

**Phone:** +49 - 40 - 67 99 47-0

**Fax:** +49 - 40 - 67 99 47 10

**e-mail:** [ist@ist-hamburg.de](mailto:ist@ist-hamburg.de)

**Internet:** [www.ist-molchtechnik.de](http://www.ist-molchtechnik.de)

If you are interested in a non-binding quotation, and would like further information about the benefits of this kind of system, perhaps including detailed comparisons with other systems, please do not hesitate to contact us. We will be pleased to send you more detailed information, or to give you advice at a more personnel level:

**I.S.T. Sales Offices:**

**Benelux**

**I.S.T. Molchtechnik GmbH**

Max Planckstraat 31  
NL - 2041 CX Zandvoort

**Phone:** +31 - 23 - 5 73 00 97

**Fax:** +31 - 23 - 5 73 03 96

**e-mail:** [kb@ist-molchtechnik.de](mailto:kb@ist-molchtechnik.de)

**Spain / South Europe**

**Xavier de BARBERÀ VAN HACHT**

C/ Fra Antoni Cardona i Grau  
7A Edif A2 6è-4a  
E - 43002-Tarragona

**Phone:** +34 - 9 77 22 87 65

**Gsm:** +34 - 6 99 43 89 23

**e-mail:** [xavier.barbera@ist-hamburg.de](mailto:xavier.barbera@ist-hamburg.de)

**U.K. / Irland**

**I.S.T. Molchtechnik GmbH**

PO Box 172  
GB - Deeside, CH5 9AN

**Phone:** +44 - 12 44 53 95 39

**Fax:** +44 - 12 44 53 97 80

**e-mail:** [istuk@ist-molchtechnik.de](mailto:istuk@ist-molchtechnik.de)