



PharmaLine DO AF H

UV DEOZONATION FOR PURIFIED WATER DISTRIBUTION LOOPS

Our **PharmaLine DO AF H** UV systems are designed for hygiene based on cGMP principles specifically for providing ozone destruction for pharmaceutical purified water distribution loops. When installed in a distribution loop the PharmaLine DO AF H will remove residual ozone dosed into the water to maintain microbiological integrity. The UV system can be remotely controlled to turn off to allow residual ozone to treat the purified water loop during a SIP and then be turned on again to remove the ozone before the loop is put back into service. Each system comes with a UV monitor/UV sensor to measure the lamp output making it easy to monitor and log performance. The UV systems are all single lamp design with long lamp life providing reduced operating costs.



Application
Optimised UV for
Pharmaceuticals

POTENTIAL LOCATIONS OF THE PHARMALINE DO AF H™

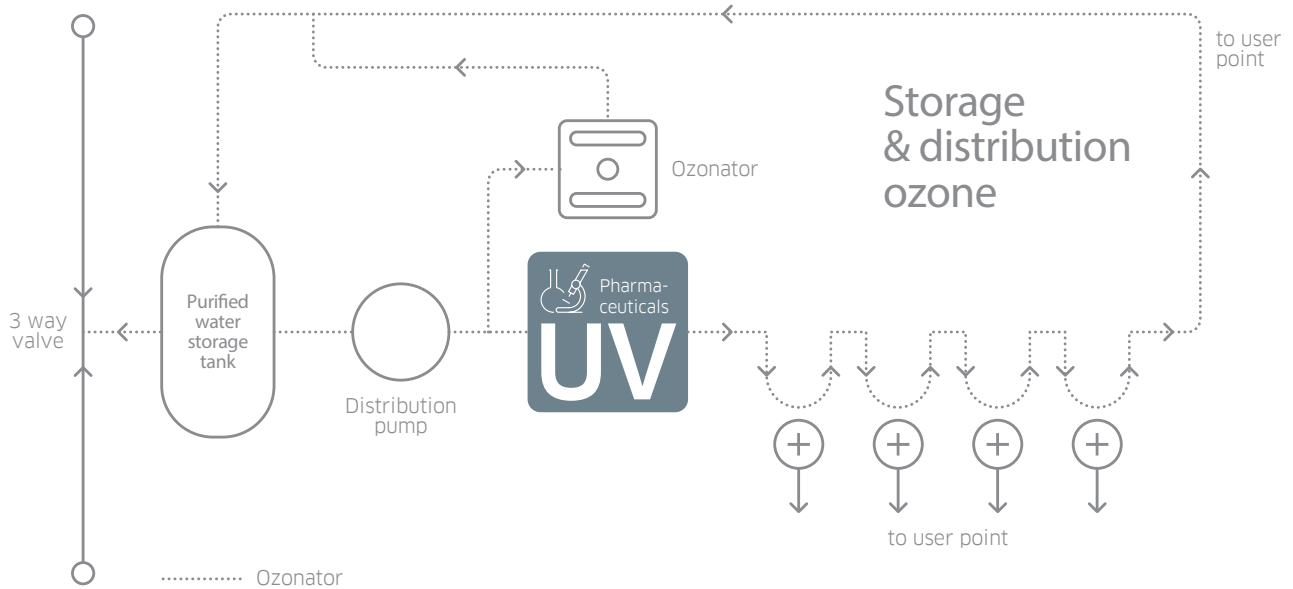

KEY FEATURES	WHAT IT GIVES YOU	BENEFITS FOR YOU
INTELLIGENCE		
UV intensity monitor / sensor measuring UV wavelengths	Continuous verification of performance with in-built low intensity alarm	Easy to monitor and log system performance
OPTIMISATION		
Single lamp technology	Optimised for ozone reduction Lower power use than comparable multi-lamp systems Lower maintenance cost compared to multi-lamp systems	Proven log reduction of ozone Lower operating costs
Designed for the pharmaceutical industry based on cGMP principles	Sanitary design with <math><0.38 \mu\text{m}</math> internal surface finish and tri-clamp connections as standard FDA-approved materials used for all wetted parts Remote control function	Industry compliance; reduced risk of microbiological contamination; enhances control of your process as part of a multi-barrier system Matches automated SIP ozonation procedure
INTEGRATION		
Compact design	Can be fitted to skids Can be retrofitted to existing process	Easy integration

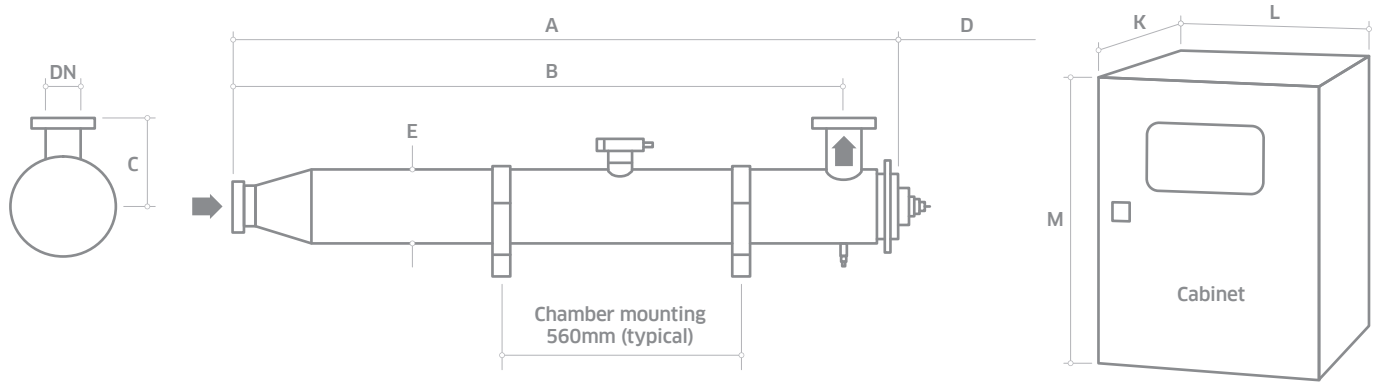

MODEL NUMBER	MAX POWER (W)	MIN T10(%)	DIMENSIONS (MM)										APPROX WEIGHT (KG)	
			A	B	C	D	E	DN	K*	L	M**	Chamber (Empty)	Control Cabinet	
PharmaLine DO AF H 0001	115	60	1388	1273	82	1300	102	40	170	300	490	9	11	
PharmaLine DO AF H 0002	165	60	1388	1273	82	1300	102	50	170	300	490	9	11	
PharmaLine DO AF H 0005	345	60	1388	1273	82	1300	102	50	170	300	490	9	11	
PharmaLine DO AF H 0008	345	60	1437	1300	150	1300	168	80	170	300	490	24	11	
PharmaLine DO AF H 0020	700	60	1980	1825	200	1900	206	80	225	400	690	46	22	

All dimensions are approximate for clearance purposes only. We have a policy of continuous product development, exact drawings are available on request. All specifications are subject to change without notification. Your distributor or our account manager can advise on correct sizing and specification requirements.

* Allow dimension L in front of cabinet for door opening and panel access.

** M dimension includes the space for the cabinet mounting brackets but you need to allow space below the cabinet for cable entry and access (minimum of 250 mm).

UV CHAMBER

Material:	StSt 316L / 1.4404
Internal finish:	<0.38 µm Ra welds left as laid, electropolished and passivated
External finish:	Sateen polish (120 grit) electropolished and passivated
Process (mating) connections:	Tri-clamp. For sizes see Tri-clamp technical bulletin 910425-0001
Drain connection:	Tri-clamp to ISO 2852
End plate:	Removable tri-clamp
Degree of protection:	IP65 equivalent to NEMA 4 but not for outside use
Arc tube (lamp):	Low pressure amalgam
Arc tube enclosure:	Pure quartz (F200)
Number of arc tubes (lamps):	1
Expected lamp life:	12000 hours
Temperature sensor:	Snap stat on DO AF H 0020 only
UV monitor:	Wet UV monitor
Working fluid temperature:	5°C to 40°C
Maximum CIP temperature:	130°C (DO AF H 0001 - DO AF H 0005) 95°C (DO AF H 0008 - DO AF H 0020) with cabinet electrically isolated
Hydrostatically pressure tested:	Yes to PED requirements EN 13445
Chamber mounting:	Horizontal or vertical except DO AF H 0020 which is horizontal only
Operating pressure:	10 bar (positive pressure only)
Seals:	EPDM, FDA 21 CFR 177.2600, USP Class VI 121°C approved

OPTIONS

Document Support Pack
Cabinet material: Stainless steel 304
Operation and Maintenance manual and printed Installation and Commissioning manual in Chinese, English, French, German and Spanish
Maximum CIP temperature: 130°C (DO AF H 0008 - DO AF H 0020, panel switched off)
Welder Document Pack for chamber construction
Skid mounting (not shipboard or earthquake zone)

CABINET (CONTROLLER ELECTRON RCM)

Material:	Polyester coated carbon steel
Degree of protection:	IP66 / NEMA 4 except DO AF H 0020 which is IP54 NEMA 12
Supply voltages (nominal):	230 V (+/- 10%) 50/60 Hz
Operating temperature range:	5°C to 40°C
Relative humidity:	<95% non-condensing, except DO AF H 0020, which is 85%
Cooling fans:	DO AF H 0020 only
Interconnecting cable lengths:	5 m

CUSTOMER OUTPUTS

4-20 mA passive output:	UV intensity %
VFC outputs:	Lamp ON and Low UV warning

CUSTOMER INPUTS

VFC inputs:	Remote stop/start and remote reset
-------------	------------------------------------

CUSTOMER COMMUNICATIONS PORT

None

APPROVALS

CE marked



PharmaLine DO AF H

Also available in our Pharmaceutical product range...



**PHARMALINE
PQ+PQH**

3rd party bioassayed systems for critical treatment or as part of a pathogen barrier



**PHARMALINE
D+DH**

Treatment as part of a multi barrier approach or secondary hygiene maintenance



**PHARMALINE
DC**

Chlorine removal

Canada

+1 980 256 5700
americas@nuvonicuv.com

China

+86 216 167 9599
apac@nuvonicuv.com

Germany

+44 175 351 5300
emea@nuvonicuv.com

Malaysia

+60 16 440 8834
sea@nuvonicuv.com



Mexico

+1 980 256 5700
americas@nuvonicuv.com

United Kingdom

+44 175 351 5300
emea@nuvonicuv.com

USA

+1 980 256 5700
americas@nuvonicuv.com



NUVONIC

A Halma company

formerly Aquionics, Berson, Hanovia and Orca GmbH

