

PharmaLine PQ AF

BIOASSAYED UV TREATMENT FOR PRE-PROCESS WATER

Our **PharmaLine PQ AF** systems are aimed specifically at providing third party bioassayed UV treatment for Purified Water Generation System Pre-treatment where sanitary design is not critical. You can be certain that the UV dose being produced will treat the water, eliminate objectionable organisms, reduce the bio-burden, protect against bio-fouling, lead to fewer CIP / SIP cycles. Equipped with a certified dry UV sensor and UVGuard™ sensor window for UV performance review. The UV sensor measures the active output of the system and a UV dose read out makes it easy to monitor and log performance. Low-pressure amalgam lamps provide an energy efficient wavelength, long lamp life to reduce operating costs. The control system also can take flow and transmittance meter inputs and calculate the UV dose based on real time operating conditions.



Application
Optimised UV for
Pharmaceuticals

POTENTIAL LOCATIONS OF THE PHARMALINE PQ AF™

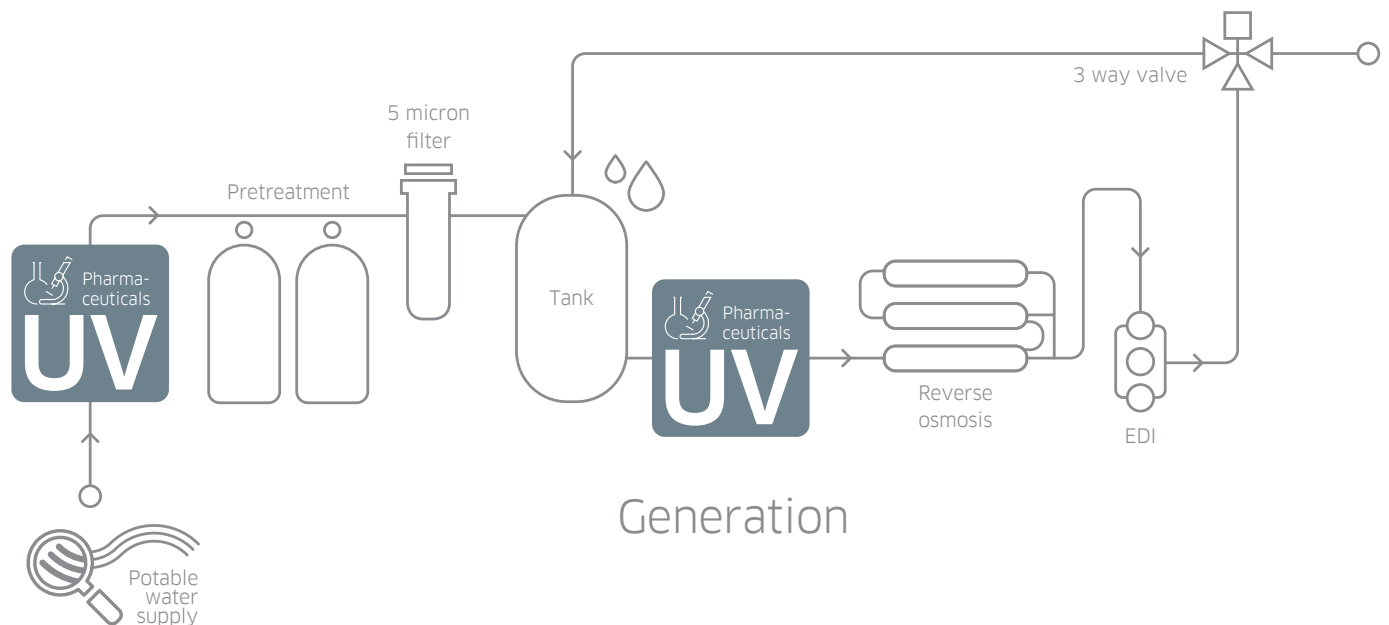

KEY FEATURES	WHAT IT GIVES YOU	BENEFITS FOR YOU
INTELLIGENCE		
Dry DVGW approved UV sensor measuring active wavelengths	Continuous verification of performance with real time RED dose reading and in-built low dose warning	Easy to monitor and log system performance
UVGuard™ on UV sensor window	Protects against UV exposure when checking a UV duty sensor with a reference sensor while the system is operating	Ability to safely audit the UV performance without interrupting production
UVShield™ on chamber*	Indication of lamp on. Power cut out on lamp access. Ability to add water leak detection	UV lamp status on chamber. Enhanced safety for lamp access. Ability to add water leak detection
Flow and UV transmittance (UVT) meter inputs	Dose reading based on actual process conditions when meters are connected	Accurate UV dose reading guaranteed under wide range of operating conditions
Option of using a transmittance compensating third party dose equation	Ability to calculate RED dose compensating for changes in transmittance without a transmittance meter	Accurate UV dose reading guaranteed under wide range of operating conditions without adding a UV transmittance meter
OPTIMISATION		
Third party bioassayed UV systems tested in accordance with USEPA protocols	UV system dose equations and sizing have been independently derived	Confidence the system will perform as stated
Single low pressure amalgam lamp technology (LPHO)	Targeted microbiological wavelength	Proven log reduction of microorganisms as part of a multi-barrier purified water process Reduced bio-burden in pre-treatment equipment leading to fewer CIP / SIP cycles and optimised production efficiency Protects RO membranes from bio-fouling, reducing CIP frequency and downtime
Designed for pre-treatment processes in the pharmaceutical industry	Flanged connections, standard internal finish	Reduced system cost where sanitary design is not critical
	FDA-approved materials used for all wetted parts	Industry compliant materials
INTEGRATION		
Compact design	Can be fitted to skids Can be retrofitted to existing process	Easy integration
RS 485 Modbus *Option	Single cable connection to customer control system	

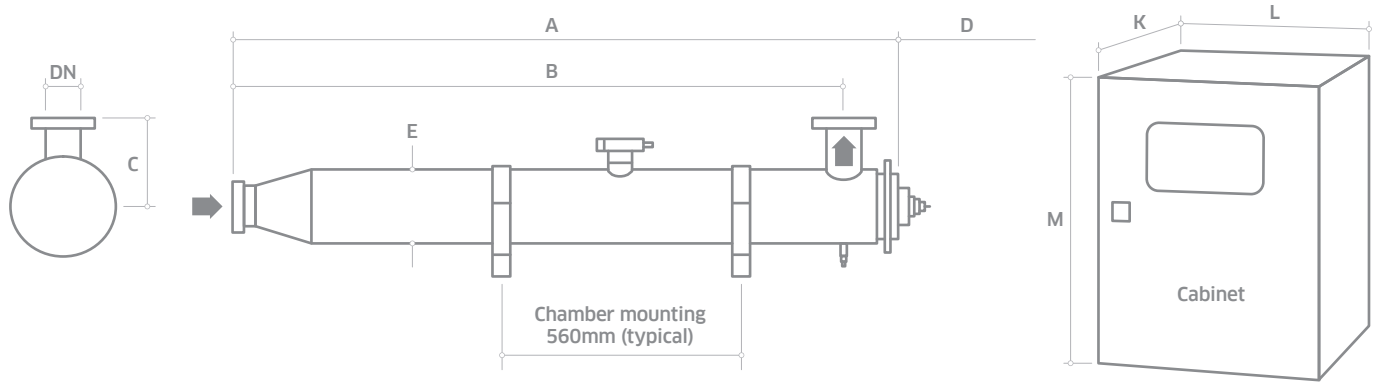

MODEL NUMBER	MAX POWER (W)	MIN T10(%)	DIMENSIONS (MM)										APPROX WEIGHT (KG)	
			A	B	C	D	E	DN	K*	L	M**	Chamber (Empty)	Control Cabinet	
PharmaLine PQ AF 0005	125	60	1388	1273	82	1300	102	40	224	600	890	9	36	
PharmaLine PQ AF 0008	200	60	1388	1273	82	1300	102	50	224	600	890	9	36	
PharmaLine PQ AF 0016	350	60	1388	1273	82	1300	102	50	224	600	890	9	36	
PharmaLine PQ AF 0030	350	60	1437	1300	150	1300	168	80	224	600	890	24	36	
PharmaLine PQ AF 0090	750	60	1980	1825	200	1900	206	150	224	600	890	46	36	

All dimensions are approximate for clearance purposes only. We have a policy of continuous product development, exact drawings are available on request. All specifications are subject to change without notification. Your distributor or our account manager can advise on correct sizing and specification requirements.

* Allow dimension L in front of cabinet for door opening and panel access.

** M dimension includes the space for the cabinet mounting brackets but you need to allow space below the cabinet for cable entry and access (minimum of 250 mm).

UV CHAMBER	
Material:	StSt 316L / 1.4404
Internal finish:	As made pipe and tube, welds as laid, electropolished and passivated
External finish:	Sateen polish (120 grit) electropolished and passivated
Process (mating) connections:	Flange EN 1092-1 PN16
Drain connection:	Tri-clamp to ISO 2852
End plate:	Removable tri-clamp except PQ AF 0090 which is flanged
Degree of protection:	IP65 equivalent to NEMA 4 but not for outside use
Arc tube (lamp):	Low pressure amalgam
Arc tube enclosure:	Pure quartz (F200)
Number of arc tubes (lamps):	1
Expected lamp life:	12000 hours
Temperature sensor:	Yes
UV sensor:	Dry DVGW compliant UV sensor with UVGuard™ window
Working fluid temperature:	5°C to 40°C
Maximum CIP temperature:	130°C (PQ AF 0005 - PQ AF 0016) 95°C (PQ AF 0030 - PQ AF 0090) with cabinet electrically isolated
Hydrostatically pressure tested:	Yes to PED requirements EN 13445
Chamber mounting:	Horizontal only
Operating pressure:	10 bar (positive pressure only)
Seals:	EPDM, FDA 21 CFR 177.2600, USP Class VI 121°C approved

OPTIONS	
Transmittance compensating dose equation	
Document Support Pack	
Cabinet material: Stainless steel 304	
Operation and Maintenance manual and printed Installation and Commissioning manual in Chinese, English, French, German and Spanish	
Wiper: Automatic (pneumatically driven)	
Flange options: ANSI 150, JIS, Table 'E' and tri-clamp with chamber internal finish <0.38 µm, welds left as laid, electropolished and passivated	
UL Listing	
UL 508A panel shop	
UVShield™	
Water leak detection	

OPTIONS (CONTINUED)	
Lead length: 20 & 29 m PQ AF 0005 - 0008, 14 m PQ AF 0016 - 0090	
Maximum CIP temperature: 130°C (panel switched off)	
In-field UV reference sensor kit	
Welder Document Pack for chamber construction	
Bleed: Hygienic valve with tri-clamp connection	
Skid mounting (not shipboard or earthquake zone)	

CABINET (CONTROLLER UVTRONIC)	
Material:	Polyester coated carbon steel
Degree of protection:	IP66 / NEMA 4
Supply voltages:	230 V (+/- 10%) 50/60 Hz
Operating temperature range:	5°C to 40°C
Relative humidity:	<95% non-condensing
Cooling fans:	No
Interconnecting cable lengths:	10 m
Variable power:	Stepless variable power on PQ AF 0090 only (40% reduction from max ballast power, 20% dose reduction)

HMI/CONTROL	
Display:	4 line LCD, indicating system status including alarms
Operating menu:	3 levels with password protection
Fault finding:	Event log

CUSTOMER OUTPUTS	
4-20 mA passive outputs:	UV dose and UV intensity
24 V dc 10 mA max outputs:	Lamp ON, any trip, any warning, system ready, system in remote, bleed valve

CUSTOMER INPUTS	
4-20 mA passive or active input:	Flow meter and transmittance meter input
VFC inputs:	Remote stop/start and remote reset

CUSTOMER COMMUNICATIONS PORT	
RS 485:	Modbus

APPROVALS	
CE marked	



PharmaLine PQ AF

Also available in our Pharmaceutical product range...



**PHARMALINE
DC**

Chlorine removal



**PHARMALINE
D+DH**

Treatment as part of a
multi barrier approach
or secondary hygiene
maintenance



**PHARMALINE
DO**

Ozone removal and
treatment

Canada

+1 980 256 5700
americas@nuvonicuv.com

China

+86 216 167 9599
apac@nuvonicuv.com

Germany

+44 175 351 5300
emea@nuvonicuv.com

Malaysia

+60 16 440 8834
sea@nuvonicuv.com



Mexico

+1 980 256 5700
americas@nuvonicuv.com

United Kingdom

+44 175 351 5300
emea@nuvonicuv.com

USA

+1 980 256 5700
americas@nuvonicuv.com



NUVONIC

A Halma company

formerly Aquionics, Berson, Hanovia and Orca GmbH

