

# Why Miyano?



TECHNOLOGY OF CITIZEN MACHINERY

**CITIZEN**  
Micro HumanTech



Exterior of the BNE-51MSY

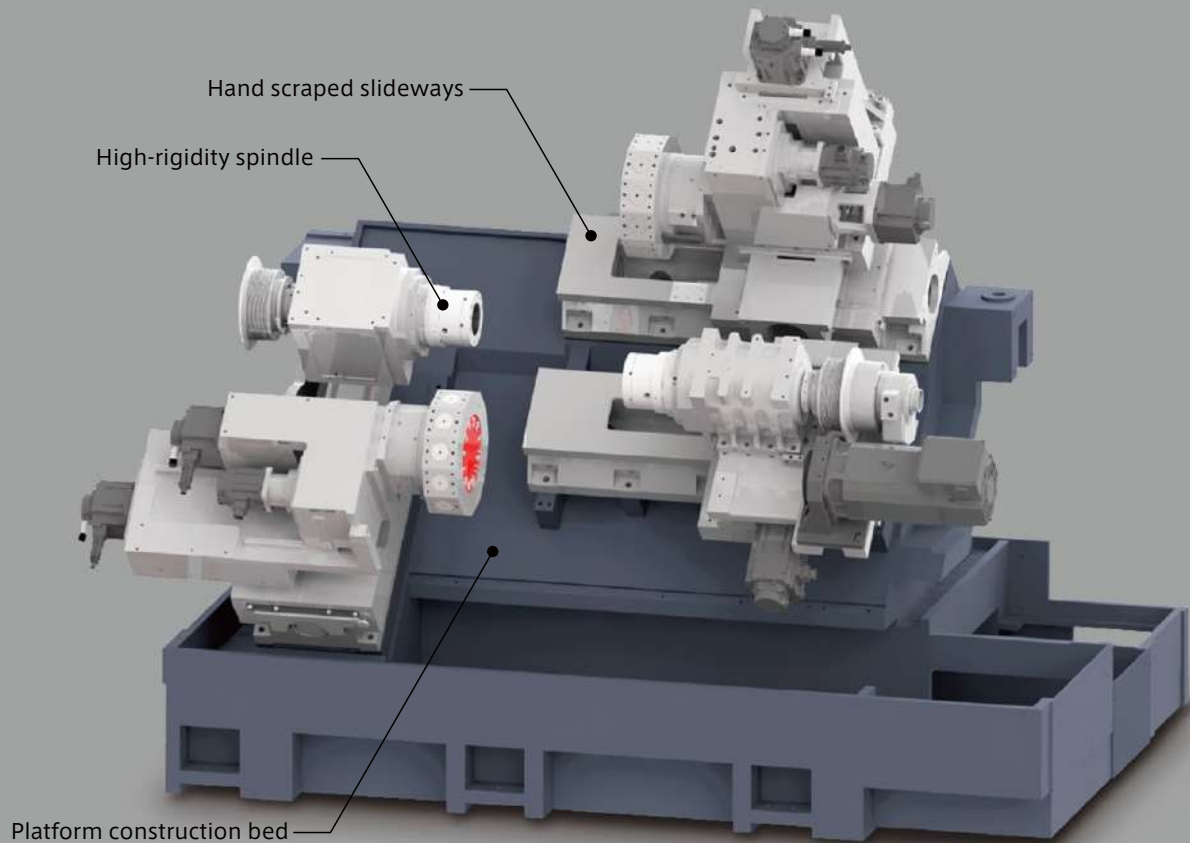

Basic construction of the BNE-51MSY

## What are MIYANO's strengths?

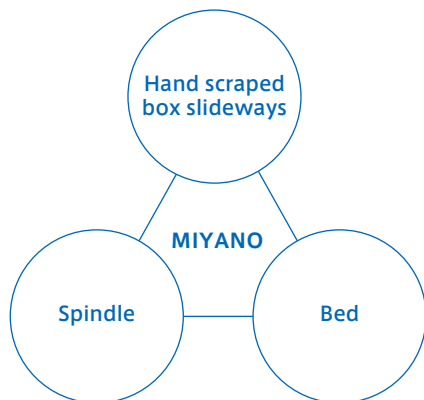

To talk about the strengths of MIYANO, a brand from Citizen Machinery Miyano's world famous machine tool product lines, we first have to go back to its roots which lie in the manufacture of precision files that were hand tools produced for use in industrial applications.

Making use of its technology, from 'MIYANO files' becoming the envy of many professional workmen at the time, MIYANO began to produce spark wheels for cigarette lighters. Here, the indispensable factor to produce the precision and exceptionally durable spark wheel was the use of highly rigid, precise and exceptionally durable automatic lathes. And since 1948, when MIYANO produced the AL-S25, the first cam-type automatic lathe to be made in Japan, the company has focused on continuous improvement in performance.

MIYANO has since cultivated three main characteristics for its machine tools: high accuracy, high rigidity and high durability. These factors have been very successfully demonstrated in the manufacture of automotive and other medium-sized precision parts that have become the brand's strength leading to great acclaim both in Japan and overseas.

Currently, the major features of MIYANO products lie in high rigidity spindles, hand scraped slideways and a platform style construction of the machine bed-all traditions that MIYANO has passed down to the present day.



The keystone for machining:  
high-rigidity spindles



# Manufacturing faithful to the 'fundamentals' imparts high rigidity and high accuracy.



Adoption of large-diameter bearings

## Optimum bearing combinations

One of MIYANO's major characteristics is the high rigidity spindle design that is the keystone to machining. Spindles with a thick-walled construction and large diameter bearings minimise deflection and enable continuously stable operations. The combination of precision double-row cylindrical roller bearings that bear radial loads and precision angular contact ball bearings that maintain high precision and a stable rotational accuracy are also key elements.

Moreover, MIYANO's unique construction ensures there are influences on machining accuracy from longitudinal displacement due to heat generation. Numerous technologies such as these enable powerful cutting and the delivery of sufficient rigidity to support the mounting of a heavy duty 8-inch chuck. Since the rigidity of the spindle contributes to improved damping characteristics of the machine construction (vibration is easily attenuated) it also helps to extend cutting tool life and reduce running costs. Maintaining stable rotational accuracy improves the quality of machining, giving higher performance in mass production operations and therefore helps reduce the workload of the operator.

## Strict quality control

These processes are not special, but rather fundamental to the design and manufacture of MIYANO machine tools. An important task in spindle assembly is the fitting of the bearings. Applying the appropriate preload during the fitting increases the rigidity and run-out accuracy thus helping to maintain machining stability. The fitting of cylindrical roller bearings, which require a high level of skill, is carried out by very experienced technicians. The grease that is injected into the bearings plays an important role in maintaining the rotational accuracy coupled with controlled test running during initial operation. This test running is performed around-the-clock, while controlling any temperature rise, to ensure the grease that was injected into the bearings settles giving a stable rotating accuracy. 'Faithfulness to the fundamentals' is what characterises MIYANO manufacturing.



Test running under strict temperature control

## Quill construction gives excellent maintainability

The quill construction should be considered as one that limits machine downtime and offers high production efficiency. MIYANO spindles are not secured directly to the machine headstock instead, a 3-step quill construction has been adopted so ideal levels of maintenance is ensured. When a spindle has to be replaced on a standard automatic lathe, the spindle bearings are re-assembled at the customer's factory leading to the machine being out of production for an extended period. By using a quill construction, the only work involved is to remove the spindle assembly and replace it with a new one which takes about half a day's work.



Example of a workpiece realized with the highly rigid spindle  
Construction machinery component (hydraulic part)

## Workpiece examples

The end faces of these components commonly feature large diameter tapped holes of M12 or greater which can often lead to slippage in the chuck or tap breakage.

MIYANO machines feature highly rigid spindles which are designed to accommodate large diameter tapping work. For example, the entire machining sequence of a hydraulic spool can now be completed on a single machine operation.



**MIYANO's key technology:  
hand scraped slideways**

## The scraping work undertaken by skilled technicians ensures high rigidity, high accuracy and long life.

### Scraping work that underpins hand scraped slideways



Scraped face of a hand scraped box slideway

Hand scraped slideways are a key technology area where MIYANO takes pride. The exceptional rigidity and damping characteristics of these slideways provide a surface contact over a wide area, not only to enable powerful cutting such as required for hard turning operations, but also to extend the life of cutting tools. In scraping, the allowance removed per scraping is as minute as 2 microns with slideway surfaces hand finished while checking contact areas by applying red or vermillion dye. It can take up to 10 hours dependant on the stroke of the machine, to complete a single slideway. With box slideways, scraping is performed across three contact faces per side in order to compose a single axis which means a total of six locations have to be scraped. Here skilled technicians take responsibility for all scraped surfaces and in order to eliminate any individual differences, the scraping work is quantitatively managed by measuring the thrust required.

### High frequency induction hardening of slideways



Hardening of slideways

When materials of the same composition and hardness slide against each other, galling can occur. Sometimes a resin-based material is affixed to the slideway but this has the demerit that the material wears quickly which over long periods of operation affects machining accuracy. Also, the coefficient of thermal expansion is different from metal and therefore movement of the slideway can be influenced by any fluctuation in temperature. MIYANO focuses on metal fitting technologies and prevents galling by subjecting the rail slide (convex side) of the slideway to high frequency induction hardening and annealing.

### Exceptional maintainability

Ease of maintenance is a major characteristic of hand-scraped slideways. When repairing age-related wear on rolling slideways, the guide set has to be replaced which takes a long time and is very expensive. With hand-scraped slideways on the other hand, high precision machining can easily be recovered simply by adjusting the gibs. Some customers have even maintained levels of accuracy for more than 10 years by simply adjusting the gibs themselves.

### Workpiece examples

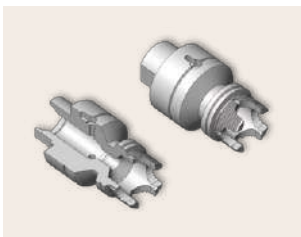

Example of a workpiece realized with hand scraped slideways  
Automobile parts

Automotive parts are relatively commonly made from materials with high hardness and toughness such as S45C, SCM or hardened materials which require hard turning. These are therefore difficult to machine while maintaining high orders of accuracy. Here, MIYANO machines characterised by their hand scraped slideways have a track record of being adopted by many automotive manufacturers and thus especially adept at machining parts for transmissions, ABS, airbags and turbochargers.

The “platform construction bed” supports spindles and turrets.

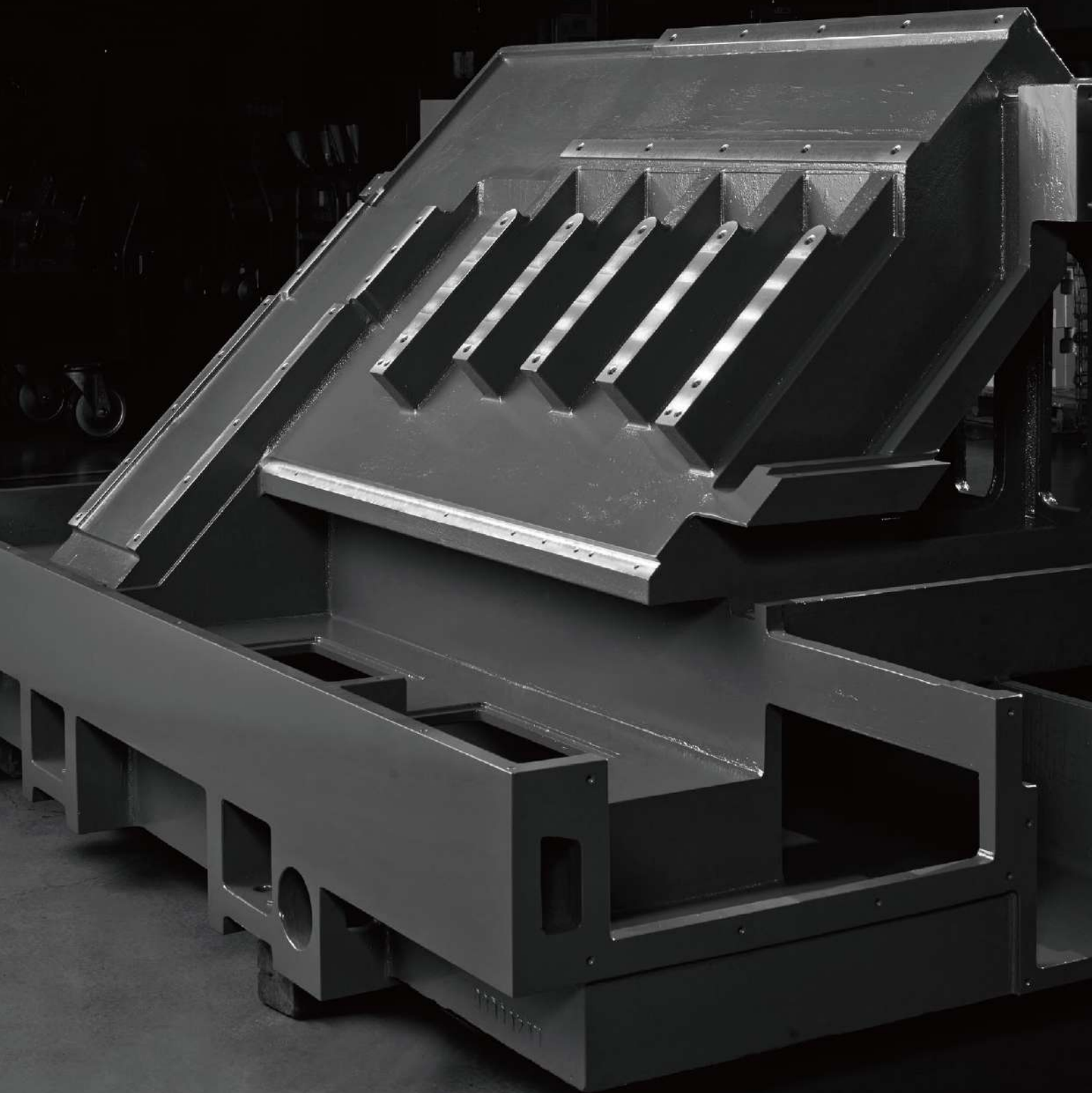



## Prioritizing machining accuracy, yet meeting even more demanding requirements.



Thick ribs imparting high rigidity

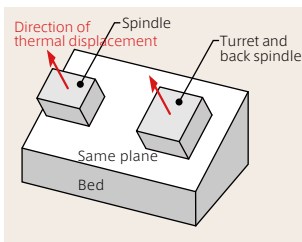

Thermal displacement  
in the same direction

### Bed with a 'platform' construction

The 'platform' refers to a reference flat surface such as a surface plate used for inspecting and measuring components. MIYANO has adopted a construction that models the 'platform' making it possible to maintain a stable flatness over the longer term. Ribs (elements fixed at right angles to the face) help to suppress deformation. The heavy construction of the bed which includes the ribs is also an important feature helping to achieve excellent rigidity and damping characteristics. Mounting the spindles and turrets on this highly stable, smooth and uniformly flat surface (slanted at 30 deg) minimises distortion of the units mounting faces due to heat generated from each of the components. Even if the individual units do thermally expand, the associated displacement is in the same direction (perpendicular to the mounting face) so the relative distortion between the workpiece and the cutting tool is suppressed.

### Integrated tank

MIYANO continues to use coolant tanks that are integrated with the machine bed. This prioritizes machining accuracy. The problem normally associated with integrated coolant tanks is that any heat from the coolant is transferred directly into the bed. MIYANO avoids this problem by adopting a structure whereby the coolant is distributed in a uniform fashion around the bed thus minimising any differences in temperature between individual parts and suppressing any deformation of the bed. The tank also has a synergistic effect with the thick bed as warmed coolant is slow to cool down thus suppressing any influence of abrupt temperature change. With regard to working convenience, the task involved in collecting chips has been reduced by sorting the chips with fine mesh filters and by designing the ribs so as not to obstruct the chip collection in the tank. For customers wishing higher efficiency chip processing, MIYANO recommends the installation of the optional chip conveyor.

### Thermorevision suppressing changes in dimensions

The use of MIYANO's Thermorevision system on the platform construction bed is designed to help customers who demand even higher levels of machining accuracy. The unit is able to accommodate dimensional changes due to thermal displacement by measuring the temperature of each part using sensors installed inside the machine. Any changes are compensated by setting the coefficient according to the type of coolant being used. In order to compensate correctly, it is important to know the characteristics of the machine and how to apply this information which is effective due to the smooth thermal displacement control of MIYANO machines.

### Workpiece examples

Brass is commonly used for water faucet fittings and hydraulic couplings. In order to shorten cycle times, form tools are often used however, due to the characteristics of the material, the machining load can become even greater than difficult-to-cut materials. For example, when broaching the key groove geometry on the inside diameter of coupling components for use in air conditioning units, chipping can occur due to vibration set up in the machine. The MIYANO 'platform' construction bed with its high rigidity and exceptional damping characteristics delivers a stable performance.

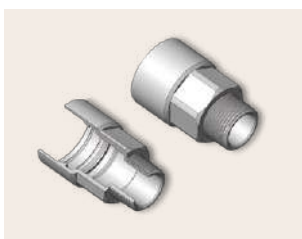

Example of a workpiece realized with  
the platform construction bed  
Water faucet fittings/couplings

# MIYANO USER'S VOICE



## Marufuji Seiko (Nishio City, Aichi Prefecture)

Members of Production Technology Team

Norio Inukai

Eiji Hijiyama

Takanori Ohno



### I think this is a well-conceived machine for making final products from bar stock.

#### The automobile component industry where efficiency is paramount

In the automotive component industry, where efficiency is a first priority, it is standard practice to increase the depth-of-cut and increase feed rate in order to shorten cycle times. "We finish the work-piece in one go incorporating rough and finish machining processes which means we need high rigidity and so we chose MIYANO. Hydraulic chucks are solid on MIYANO lathes, so the material never slips, even during machining with heavy loads and using larger sizes of drill. Even when drilling with a U-drill in excess of 10 mm diameter and a cutting feed rate of 0.25 mm/rev the operation is smooth with no slippage in the chuck. It is simple to adjust the chuck so the same accuracy is maintained and it can be changed to a collet chuck, power chuck or three-jaw chuck simply by changing the chuck front. This means we can rest assured that we can prepare for another set up whenever necessary."

#### Devising more efficient chip processing

"I think that using water-soluble coolant gives greater stability against thermal displacement. When water-soluble coolant is used, damage to the machine has also to be considered but with MIYANO there is no real problem. Today machining accuracy is a decimal place tougher than it was in the old days with greater use of aluminium. When machining aluminium the chips are bulky so the chip processing can be difficult. But a slant bed machine channels chips away and as the MIYANO bed has an integrated coolant tank this maintains high accuracy and minimises thermal displacement. Chip clearance can be further improved by using a drum type chip conveyor, for example."

#### Machines that are easy to use even the first time

I encountered MIYANO machines about 30 years ago with the DN-34. It was really easy to use even for the first time. Now the control screen is larger which makes it even easier to use. I think the reason that it is easy to use is that MIYANO construction is so simple. I think that it is a well-conceived machine for producing final products from bar stock."

#### Aiming to extend our coverage to bar stock larger than 50 mm

"The other day we machined a new transmission component. The material was 53.6 mm diameter steel bar stock 3 m long and weighing 50 kg. By drilling with a 25.5 mm diameter U-drill to a depth of 40 mm at the main spindle and finishing with the sub-spindle we can manage mass production with stable roundness of 10 micron. We would like to broaden our range as Marufuji Seiko is taking this opportunity to promote the fact that we can handle bar stock larger than 50 mm diameter."



## Matsuda Seiki Co., Ltd. (Kawanishi City, Hyogo Prefecture)

President,  
Masuo Shigeta

Operating Officer,  
Yuichi Kimura

Manager of Kawanishi Plant,  
Junichi Hattori



### Cutting edges last a long time even in hard turning, which leads to reduced machine down time.

#### Full operation 24 hours, even now

"We first used MIYANO machines in 1987 as we started machining ABS components for the automotive industry. We run 24 hours a day from Monday to Saturday and the machines we introduced at that time are still operating and holding dimensional tolerances of +/- 7 micron. Since we are familiar with the machine, we even maintain it ourselves as much as possible. We keep a stock of ballscrews and replace them on machines when they become worn and adjust the gibs on the hand scraped slideways. As we expected, MIYANO machines are built to last. Using competitor machines in the same way really brings this home."

#### Cutting edges last a long time even when hard turning

"The material from the ABS components that we are currently machining is SCM steel. After machining the blank from bar stock on a MIYANO BNJ and it is hardened, it is finish hard turned on an Ocean Cincom GN-4200. Since a grinding process creates difficulties in maintaining concentricity with the turned location the processes are now integrated on the single machine. When we tried this on other machines it was difficult to hold the geometric tolerances on roundness. We also found hard turning caused tools to deteriorate which increased the frequency for tool changes. So the fact that cutting edges now last a long time on the MIYANO this not only reduces our tool cost, but also helps cut machine downtime."



## Inasaka Oil Hydraulics Mfg. Co., Ltd. (Kato City, Hyogo Prefecture)

Chief of Machining Section of Manufacturing Department  
Shoichi Hattori

### Stable mass production is possible even with machining conditions that were difficult on alternative machines.

#### Trust in good thermal displacement characteristics and machine rigidity

"At Inasaka Oil Hydraulics we machine mainly hydraulic components such as spools for construction machinery. We have found year by year that the requirement for machining accuracies is becoming much tougher. However, it is important not to just focus on the locations where the tolerances are tight but to manage the total accuracy taking the dimensions after grinding into account. We have found because MIYANO machines have a substantial bed and little thermal displacement we can meet the high levels of accuracy required. We also trust the rigidity allowing stable mass production to be accomplished even under machining conditions that are considered difficult on other makes of machine."

#### Roundness of 2 micron and cylindricity of 5 micron achieved

"Previously we machined collars for pressure reducing valves for the construction industry. These were components that required extremely high accuracies with a roundness of 2 micron and a cylindricity of 5 micron for the 35 mm inside diameter. We struggled with our cutting methods and machining conditions but when we transferred parts to the MIYANO BNJ we achieved the tolerances required. Our machining technique was also important, but I think this would have been impossible if the accuracy of the machine was not sufficient"

# CITIZEN

Micro HumanTech

## CITIZEN MACHINERY MIYANO CO., LTD.

<b>JAPAN</b>	CITIZEN MACHINERY MIYANO CO., LTD. 4107-6 Miyota, Miyota-machi, Kitasaku-gun, Nagano-ken, 389-0206, JAPAN	TEL. 81-267-32-5901	FAX. 81-267-32-5908
<b>SOUTH ASIA</b>	CINCOM MIYANO ASIA SALES CO., LTD. 1230 Rama 9 Road, Kwang Suanluang, Khet Suanluang, Bangkok 10250 THAILAND	TEL. 66-23-745-226	FAX. 66-23-745-228
<b>KOREA</b>	CINCOM MIYANO KOREA CO., LTD. Room No. 105 BYUCKSAN DIGITAL VALLEY I 212-16, Guro-3dong, Guro-gu, Seoul, KOREA	TEL. 82-70-4337-1325	FAX. 82-70-8220-8539
<b>TAIWAN</b>	CINCOM MIYANO TAIWAN CO., LTD. 10Fl., No.174, Fuh Sing N. Rd., Taipei, TAIWAN	TEL. 886-2-2715-0598	FAX. 886-2-2718-3133
<b>CHINA</b>	CITIZEN (CHINA) PRECISION MACHINERY CO., LTD. 366.HENGTONG ROAD OF ZHOUCUN, ZIBO, SHANDONG, P.R.CHINA	TEL. 86-533-6150560	FAX. 86-533-6161379
<b>EUROPE-Germany</b>	CITIZEN MACHINERY EUROPE GmbH Mettinger Strasse 11, D-73728 Esslingen, GERMANY	TEL. 49-711-3906-100	FAX. 49-711-3906-106
<b>EUROPE-UK</b>	CITIZEN MACHINERY UK LTD 1 Park Avenue, Bushey, WD23 2DA, UK	TEL. 44-1923-691500	FAX. 44-1923-691599
<b>AMERICA</b>	MARUBENI CITIZEN-CINCOM INC. 40 Boroline Road Allendale, NJ 07401, U.S.A.	TEL. 1-201-818-0100	FAX. 1-201-818-1877

URL: <http://cmj.citizen.co.jp/>

All specifications are subject to change without prior notice. \*This product is an export control item subject to the foreign exchange and foreign trade act. Thus, before exporting this product, or taking it overseas, contact your CITIZEN machine dealer. \*Please inform your CITIZEN machine dealer in advance of your intention to re-sell, export or relocate this products. For the avoidance of doubt products includes whole or part, replica or copy, technologies and software. \*In the event of export, proof of approval to export by government or regulatory authority must be evidenced to CITIZEN. You can operate the machines after the confirmation of CITIZEN. CITIZEN is a registered trademark of Citizen Holdings Co., Japan.