



MTE MILLING
MACHINES

Innovative technologies designed for a global market

Flexibility to develop highly customised projects

Founded in the cradle of the machine tool in 1994 by a team with decades of experience in the industry, MTE is a young, dynamic company specialised in providing customised solutions for each customer. Our main plant is located in Gipuzkoa, an area recognised by the most demanding international markets.

The entire process is developed at our recently built 6.000 m² plant. From machine design to final assembly, including the whole range of milling heads.

We manufacture all the structural cast parts in close collaboration with local foundries that are specialists in machine tools. Consequently, we obtain components of the highest quality that give our machines excellent stability and precision.

All of this, together with our team's extensive experience and their degree of commitment to the company, means we offer a top quality product. As our main market with more than 800 machines installed, we have a branch in Montabaur, Germany's industrial heartland.



Headquarters Itziar, Gipuzkoa, Spain



Branch office Montabaur, Germany

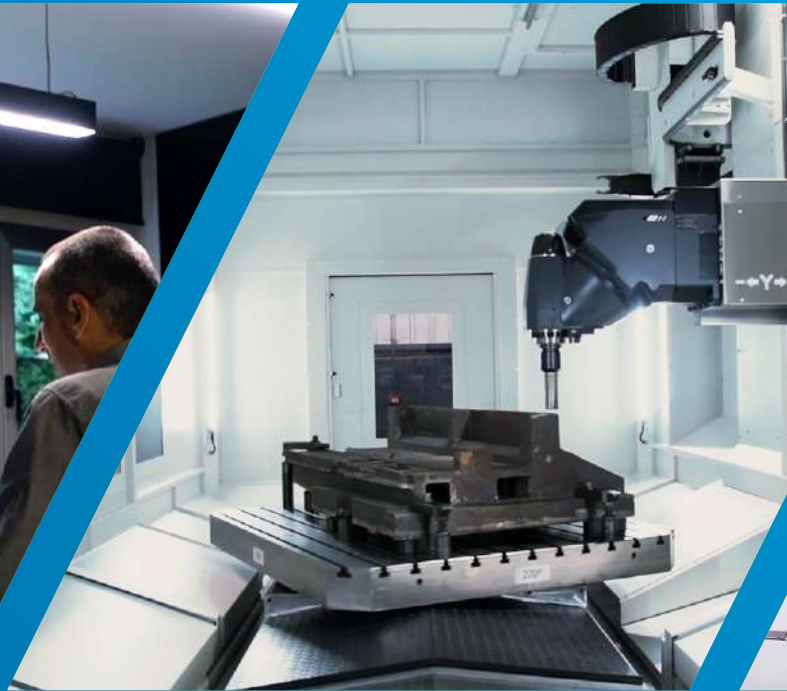

Project analysis

In communication with the customer, we study their needs and propose the best machine and configuration solution.

Machine design

We first develop a design based on the information gathered with the customer. After approval, we create 3D models that simulate the installation in detail.

Manufacturing

Our machines are assembled under the most demanding quality standards. The machining and grinding of structural pieces is verified and monitored at every step to achieve a top quality product. All components are assembled following protocols designed by our quality department.

Verification

All our machines are tested together with the end customer at our facilities and before shipment.

Commissioning

In the final phase of the project, experienced specialists carry out the installation, commissioning and final verification of the machine at the customer's premises.

K SERIES



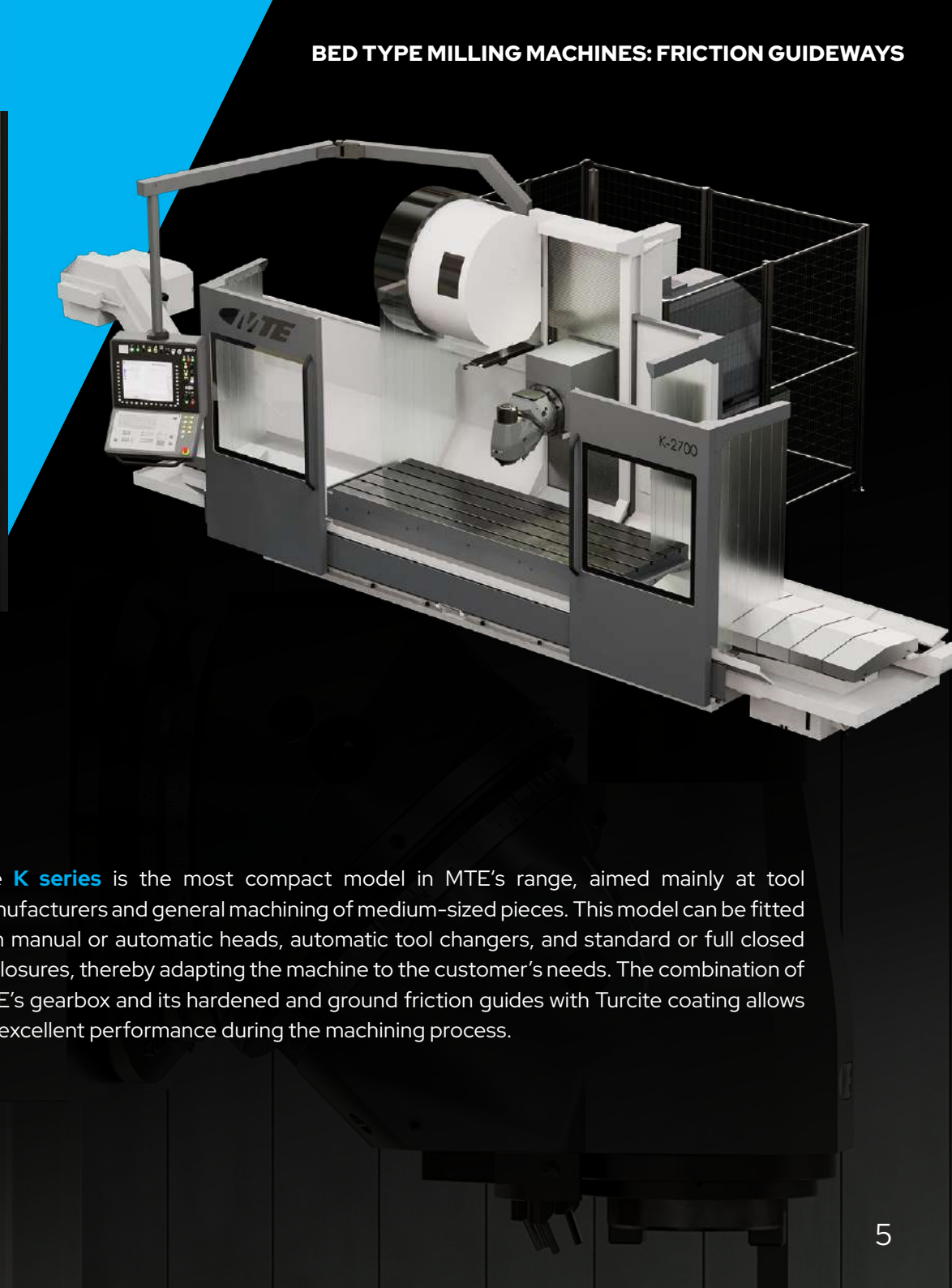
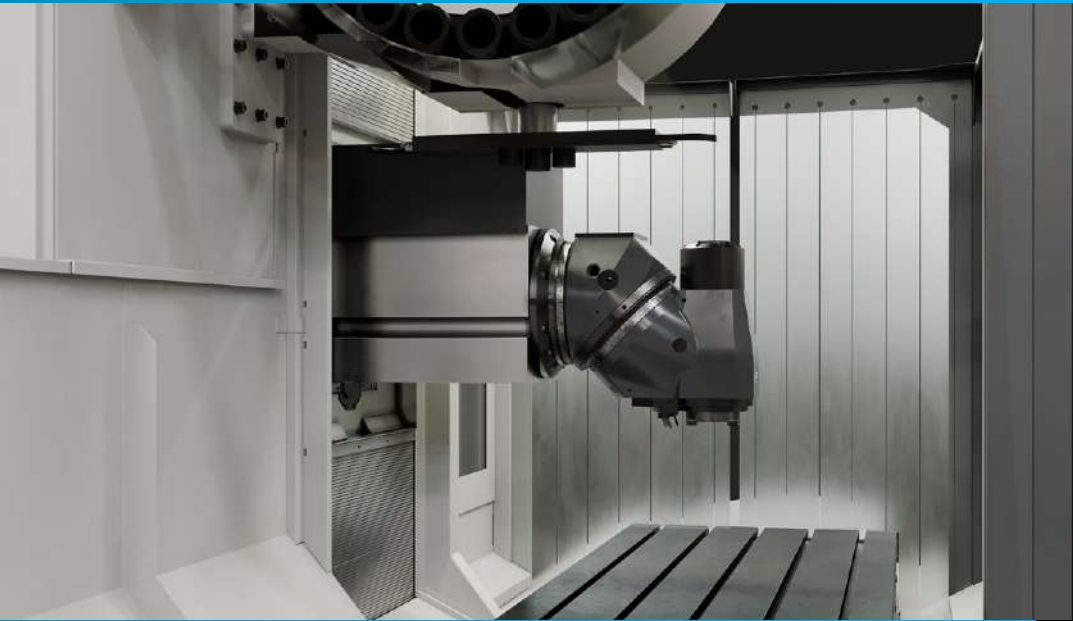

TRAVELS

X axis: 2.000 - 5.000 mm (longitudinal)

Y axis: 1.000 mm (cross)

Z axis: 1.100 mm (vertical)

TABLE

2.200 - 5.200 x 850 mm

MAIN SPINDLE

Power: 24 / 32 kW

Speed: 4.000 / 6.000 rpm

FEEDS

Maximum: 15.000 mm/min

MILLING HEADS



MFK



AFK

The **K series** is the most compact model in MTE's range, aimed mainly at tool manufacturers and general machining of medium-sized pieces. This model can be fitted with manual or automatic heads, automatic tool changers, and standard or full closed enclosures, thereby adapting the machine to the customer's needs. The combination of MTE's gearbox and its hardened and ground friction guides with Turcite coating allows for excellent performance during the machining process.

BF SERIES



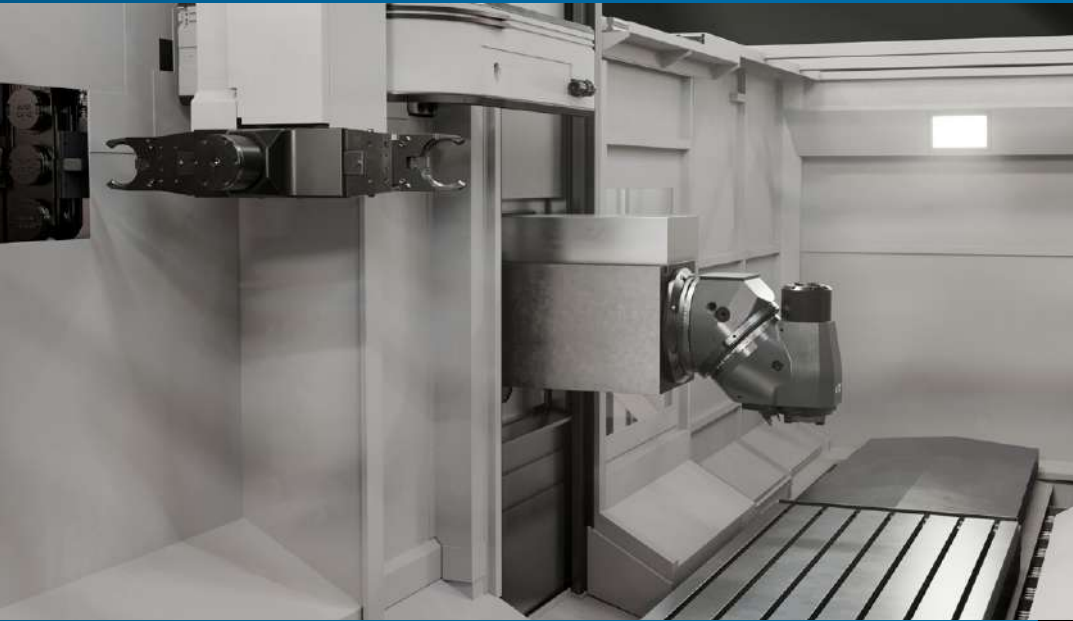

TRAVELS

X axis: 2.000 - 5.000 mm (longitudinal)

Y axis: 1.000 - 1.300 mm (cross)

Z axis: 1.000 - 2.000 mm (vertical)

TABLE

2.200 - 5.200 x 1.000 / 1.200 mm

MAIN SPINDLE

Power: 32 kW

Speed: 4.000 / 6.000 rpm

FEEDS

Maximum: 15.000 mm/min

MILLING HEADS



MFK



AFK



OFK

The **BF series** is ideal for all applications. Particularly aimed at high torque milling, mould manufacturing and universal machining. It has also been proven to be highly efficient for light welded pieces. To cover all these applications, the BF series offers large friction guides, resulting in a highly stable, precise machine. Thanks to its 3-speed cooled MTE gearbox, it achieves very high torque values.

BT SERIES



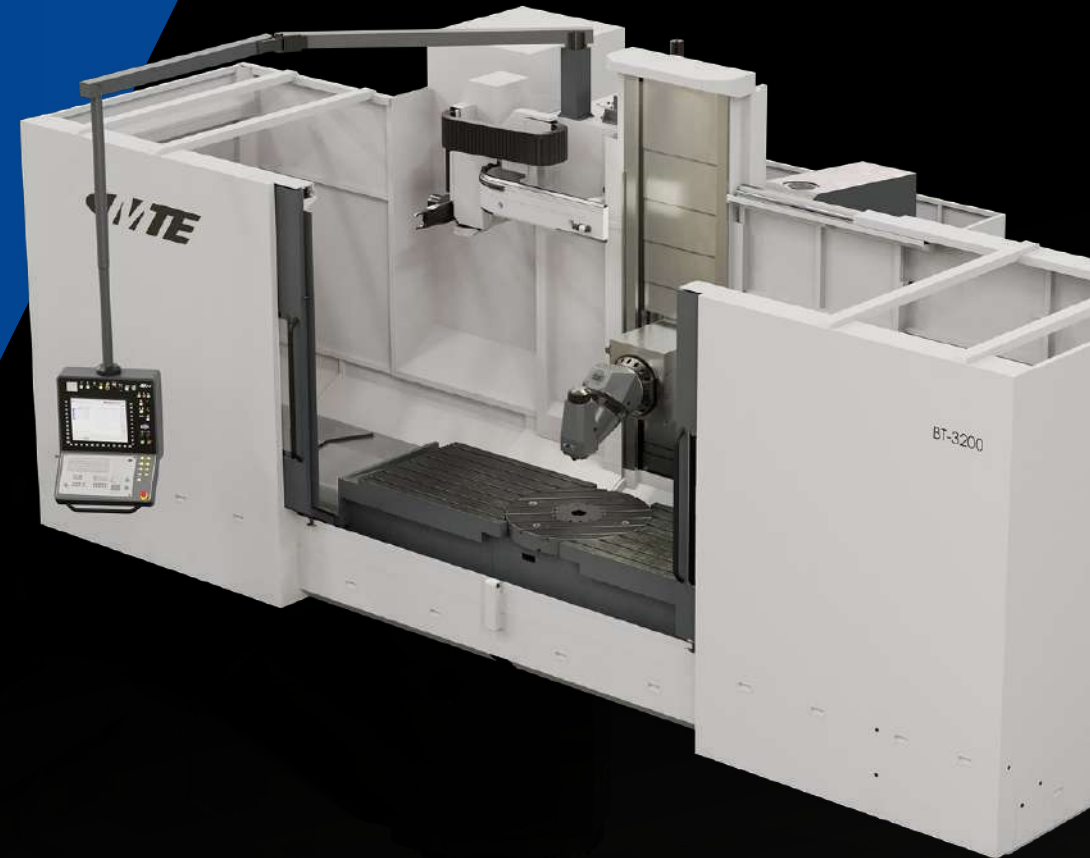

TRAVELS

X axis: 2.000 - 5.000 mm (longitudinal)
 Y axis: 1.000 - 1.300 mm (cross)
 Z axis: 1.000 - 2.000 mm (vertical)

TABLE

2.200 - 5.200 x 1.000 / 1.200 mm
 Optionally integrated rotary table for milling / turning

MAIN SPINDLE

Power: 32 / 40 / 43 kW
 Speed: 4.000 / 6.000 rpm

FEEDS

Maximum: 25.000 mm/min

MILLING HEADS



Fitted with super-precision roller guides, the **BT series** is designed for high feed rates and high speed milling, and is ideal for all applications. This is a highly stable, precision milling machine that can be equipped with rotary tables of different types with positioning and turning functions. It can also be fitted out with cutting-edge technology as respects a torque main motor, based on the concept of cooled direct drive transmission.

KT SERIES



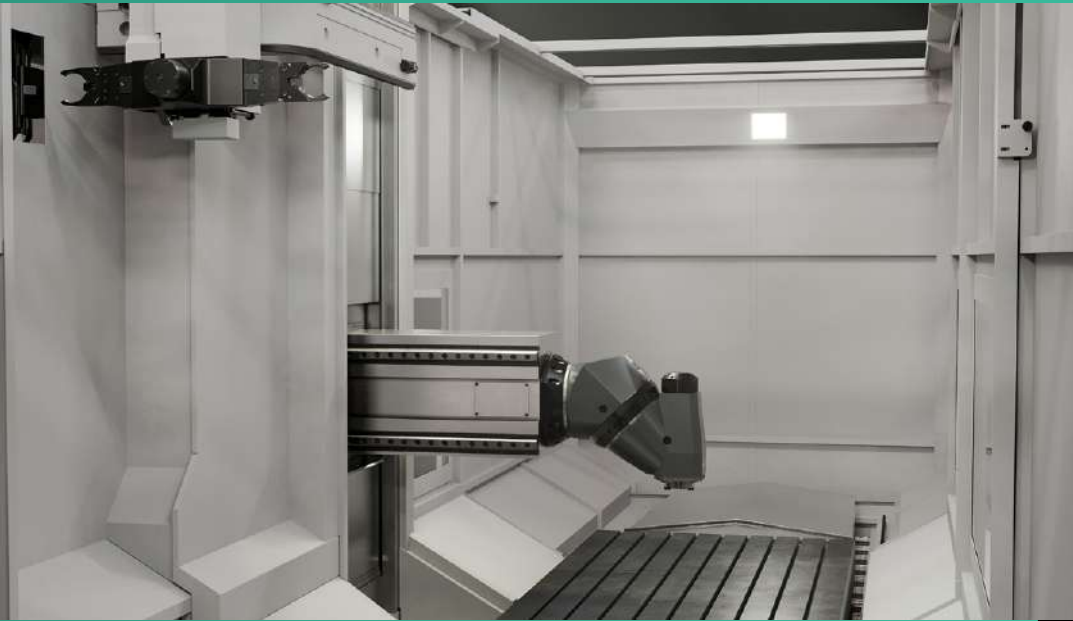

TRAVELS

X axis: 2.000 - 5.000 mm (longitudinal)

Y axis: 1.500 - 1.600 mm (cross)

Z axis: 1.500 - 2.000 mm (vertical)

TABLE

2.200 - 5.200 x 1.200 / 1.400 mm

Optionally integrated rotary table for milling / turning

MAIN SPINDLE

Power: 32 / 40 / 43 kW

Speed: 4.000 / 6.000 rpm

FEEDS

Maximum: 25.000 mm/min

MILLING HEADS



MFK



AFK



BFK



SFK



OFK

The **KT series** is the BT series' big sister, both in terms of size and features. A larger resizing allows to reach a transverse travel up to 1.600 mm. As in the BT models, it can be equipped with rotary tables of different types with positioning and turning functions.

RT SERIES

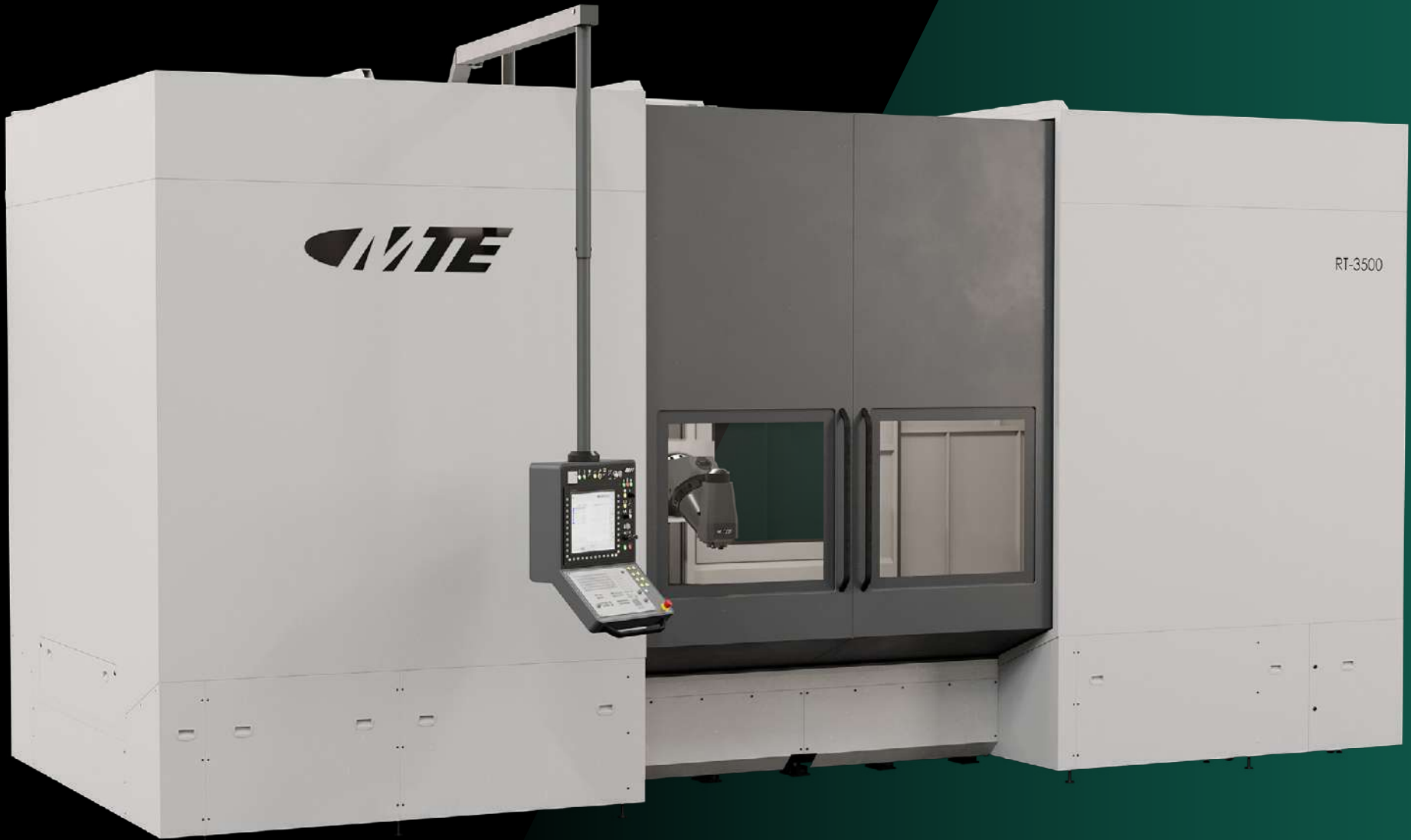

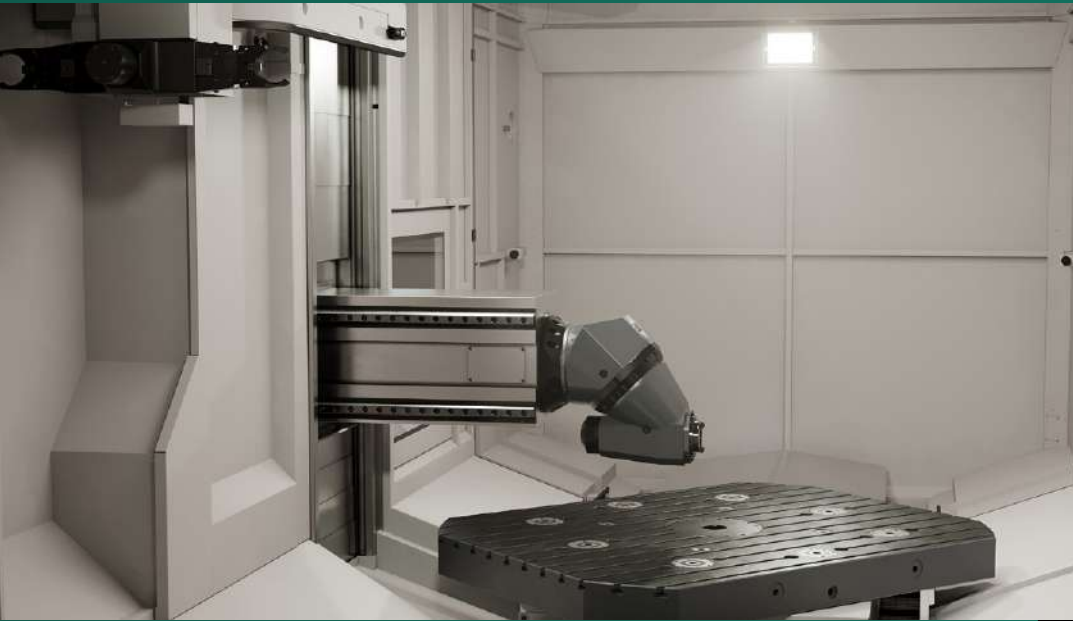

RT-V model

TRAVELS

X axis: 2.000 - 4.000 mm (longitudinal)
 Y axis: 1.200 - 1.600 mm (cross)
 Z axis: 1.500 - 2.000 mm (vertical)
 Axis W: 1.000 - 2.000 mm (RT-V)

ROTARY TABLE

1.200 x 1.500 / 1.400 x 1.600
 1.600 x 2.000 / 2.000 x 2.500 mm

MAIN SPINDLE

Power: 32 / 40 / 43 kW
 Speed: 4.000 / 6.000 rpm

FEEDS

Maximum: 25.000 mm/min

MILLING HEADS



MFK AFK BFK SFK OFK HFK

The **RT series** is based on the BT or KT model, and combines all the advantages of a boring mill with those of a milling machine. In this model, the table becomes a high-performance rotary table with excellent load capacity that, in combination with an automatic head, makes it possible to machine complex pieces on five sides and all possible angles in a single set-up. MTE also has the **RT-V** model: the solution for turning extremely long workpieces as the column can be retracted.

SB SERIES

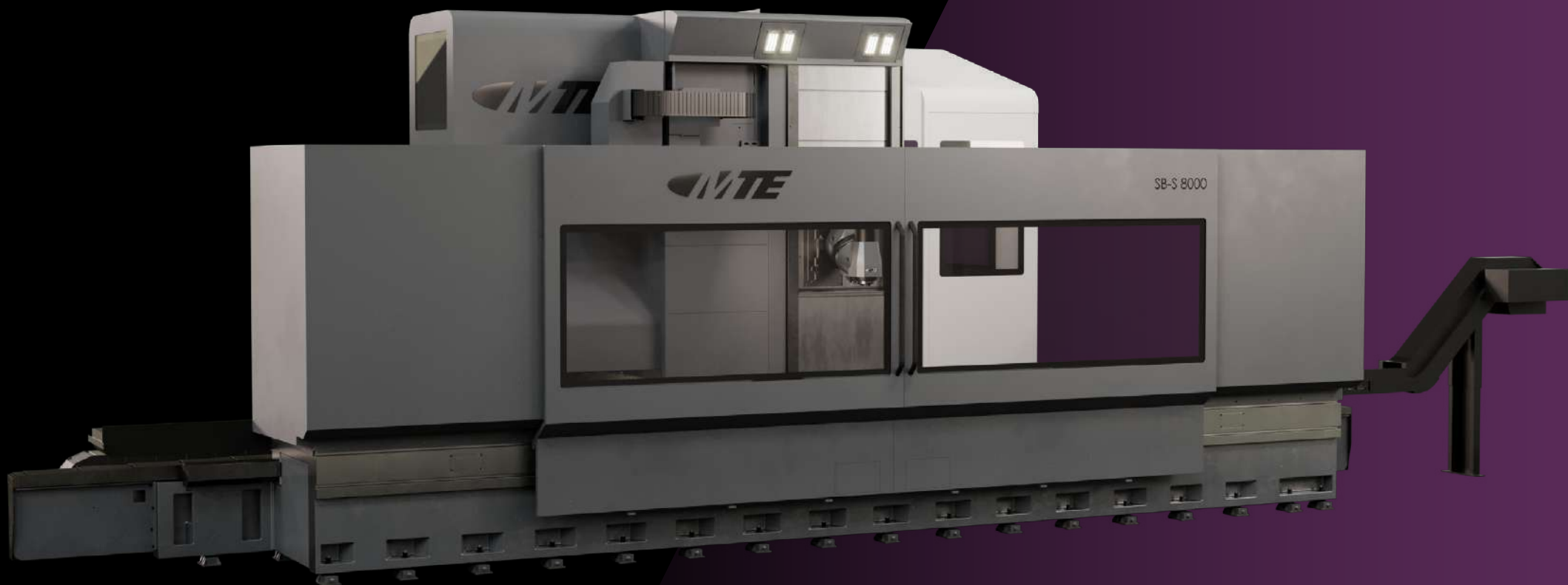

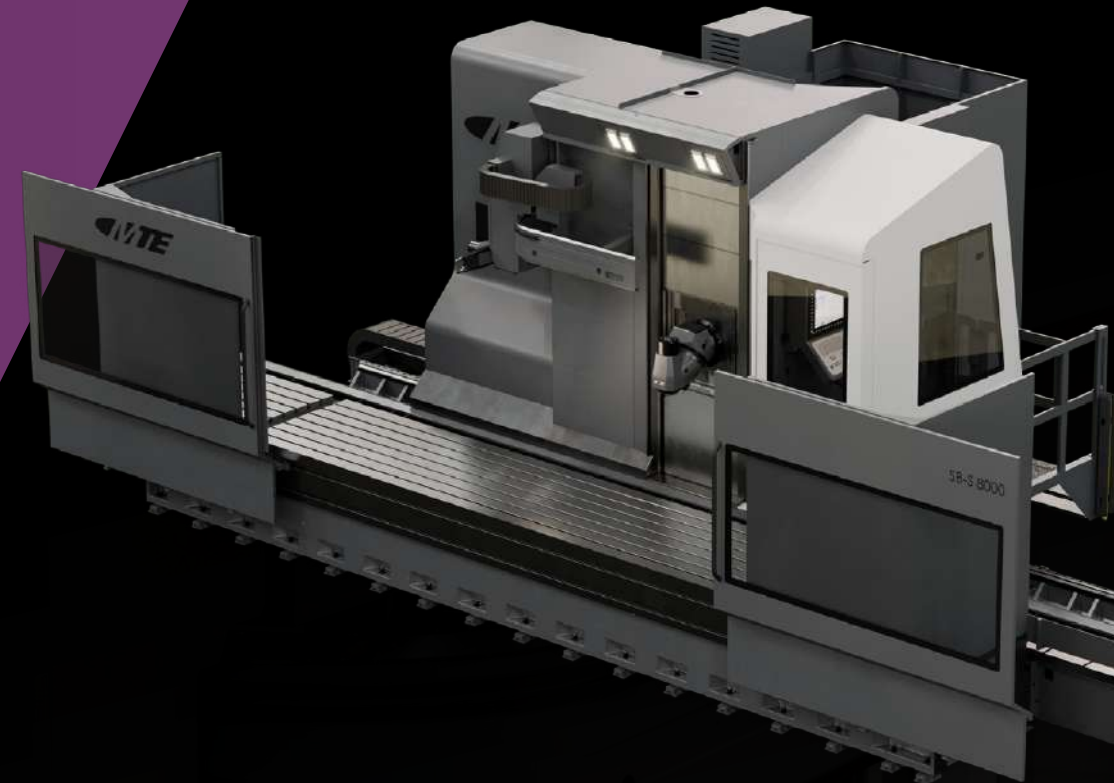

TRAVELS

X axis: 3.500 – 20.500 mm (longitudinal)
 Y axis: 1.500 – 2.500 mm (vertical)
 Z axis: 1.200 – 1.600 mm (cross)

TABLE

5.000 – 22.000 x 1.100 – 1.500 mm

MAIN SPINDLE

Power: 32 / 40 / 43 kW
 Speed: 4.000 / 6.000 rpm

FEEDS

Maximum: 25.000 mm/min

MILLING HEADS



MFK



AFK



BFK



SFK



OFK



AHC

The **SB model** combines the advantages offered by both bed type and travelling column milling machines. Its extremely rigid table, which can be fixed directly to the ground without needing major foundations, guarantees excellent stability. At a height of 850 mm, the operator can handle workpieces of different geometries and weights very ergonomically. With cutting-edge technology in terms of heads and power transmission, the SB model gives excellent results. Maximum productivity in pendular working mode, taking advantage of machining times while the next workpieces are being prepared.

FBF-S SERIES





TRAVELS

X axis: 3.000 – 36.000 mm (longitudinal)
 Y axis: 1.000 - 2.250 mm (vertical)
 Z axis: 1.000 – 1.300 mm (cross)

TABLE

Low table: 300 mm high
 High table: 900 mm high
 Rotary tables on request

MAIN SPINDLE

Power: 32 / 40 / 43 kW
 Speed: 4.000 / 6.000 rpm

FEEDS

Maximum: 25.000 mm/min

MILLING HEADS

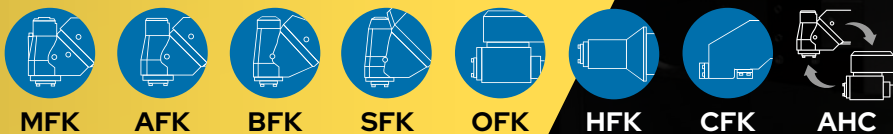

The **FBF-S series** is the first step in the floor type milling machines range. It is used for general mechanical engineering applications and, with the extensive configurations possible, is a versatile solution for all kinds of individual production. Its modular design in combination with the pendular working function makes it the ideal solution for sectors such as the railway industry. With the option of Automatic Head Change, roto-translating tables with turning option and tool changers, it provides maximum flexibility in high-precision machining of highly complex pieces.

FBF-M SERIES





TRAVELS

X axis: 4.000 – 36.000 mm (longitudinal)
 Y axis: 1.500 – 3.200 mm (vertical)
 Z axis: 1.500 – 1.600 mm (cross)

TABLE

Low table: 300 mm high
 High table: 900 mm high
 Rotary tables on request

MAIN SPINDLE

Power: 32 / 40 / 43 kW
 Speed: 4.000 / 6.000 rpm

FEEDS

Maximum: 25.000 mm/min

MILLING HEADS



Sharing the FBF-S model's versatility, the **FBF-M series** covers larger workpieces as a result of the machine's structure being re-sized. In this case, the vertical travel extends to 3.200 mm with the option of a movable operator cabin. As with the entire travelling column range, it is possible to design the machine with low tables at ground level or elevated tables for easier handling, depending on the application.

FBF-X SERIES





TRAVELS

X axis: 5.000 – 36.000 mm (longitudinal)
 Y axis: 3.500 - 5.300 mm (vertical)
 Z axis: 1.600 - 1.800 mm (cross)

TABLE

Low table: 300 mm high
 High table: 900 mm high
 Rotary tables on request

MAIN SPINDLE

Power: 40 / 43 / 62 kW
 Speed: 4.000 / 6.000 rpm

FEEDS

Maximum: 25.000 mm/min

MILLING HEADS



The **FBF-X series** brings together all the benefits of the travelling column range in a single machine with an even more robust design. In combination with size 100 guideways, the most demanding jobs are made possible and new machining heights can be reached. In this case, the vertical travel is up to 5.300 mm. Just as our machines are designed to achieve optimal performance, all the finishings are taken care of to the smallest detail.



Standard equipment

- Manual cooled head 4,000 rpm (MFK)
- CNC Heidenhain TNC 640 / TNC 7
- 19 inch touch screen
- Heidenhain direct linear scales (pressurised in SB and FBF models)
- HR-510 electronic handwheel
- Integrated security system
- CNC moveable panel front and back work area (except SB and FBF models)
- Automatic lubrication system
- CE standard enclosure
- External cooling equipment
- Electrical cabinet cooling unit (except K and BF models)
- Hydraulic counterbalance system
- Tool change pedal or ram button
- Working light with LED technology
- Precision levelling elements (except K and BF models)

Optional equipment

- Automatic head change system (for SB and FBF models)
- Other CNC: Fagor 8065M, Siemens Sinumerik ONE and Fanuc 31iB-Plus
- 2nd CNC panel in the front area
- Wireless handwheel
- Teleservice
- Random type 24 tools vertical changer
- Horizontal / vertical chain type tool change: 40, 60, 80, 100 tools
- Advanced tool magazine management
- Chip conveyors
- Coolant through the spindle 20/50 bar with pressure adjustment
- Magnetic drum filtering / Oil band skimmer + micro-oxygenator
- Air through nozzles and the spindle
- Coolant spray gun for cleaning
- 4th axis rotary tables / tailstocks
- Turning rotary tables
- Tool and piece probes: Hexagon M&H, Heidenhain, Blum and Renishaw
- Laser tool probes
- Brankamp-Artis Collision Monitoring System integrated in CNC
- MQL systems
- Pendular working system (for SB and FBF models)
- Vertical/horizontal movable operator cabin (for FBF-M and FBF-X models)
- Perimeter enclosure without or with roof (for bed type models)
- Spinning windows
- Exhaust extraction equipment (for bed type models and perimeter enclosure with roof)
- Automatic doors (for bed type models and perimeter enclosures)
- Machine status light tower

MTE Milling heads

Designed for each application

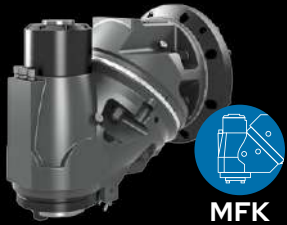

MFK

MFK Manual milling head

Index: Manual



SFK

SFK Automatic milling head

Index: Hirth coupling
Shaft B 0,001° / Shaft A 0,001°



AFK

AFK Automatic milling head

Index: Hirth coupling
Shaft B 2,5° / Shaft A 2,5° (opción 1°)



OFK

OFK Orthogonal milling head

Index: Hirth coupling
Shaft B 1° / Shaft A 1°

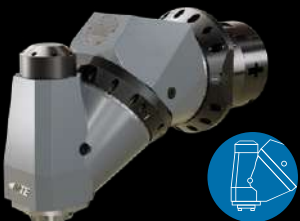

BFK

BFK Automatic milling head

Index: Hirth coupling
Shaft B 0,01° / Shaft A 0,01°



HFK

HFK Direct output

Rod length: 225 - 500 mm
Outside diameter: 198 mm

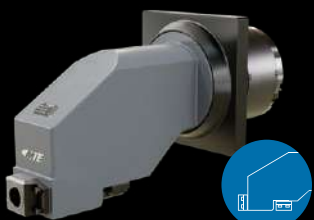

CFK

CFK Turning head

Tool holder for CAPTO C5 / C6 / C8
Automatic tool clamping in horizontal and vertical positions

Taper: SK-50 DIN69871 Big Plus®

Pool stud: ISO7388 2A

MTE Technologies

Finding solutions positions us at the cutting edge of the industry

Advanced Rotary Table Management



In machines with a pendular working mode, it enables the manipulation of rotary tables in parallel. Including cycles developed by MTE to find centre of rotary tables and plane displacement.

Advanced Tool Management



System designed for safe access to the tool magazine. Enables handling of stored tools during the machining process to maximise efficiency.

Tool Center Calibration



Cycles developed by MTE to optimise small head compensations. In combination with a probe and precise hardware, the machine is capable of self-calibration.

ECO mode



This technology avoids waste of energy, thereby achieving greater efficiency and helping the user to meet their environmental targets and reduce cost in the process.

Remote Service



In order to provide support and reduce costs, this solution enables secure and direct remote access to the machine, via a physically switchable VPN tunnel.

Automatic Head Changing system



Stored in a closed station the heads are automatically exchanged according to the needs of each application. These cycles are exclusive for SB and FBF machines.



Providing a customised service is our hallmark

Technical support

Our specialists and engineers are always available to help with any needs you may have. Whether it is maintenance of our milling machines or finding a way to improve processes, we will be happy to help.

Providing a customised service is our hallmark; it drives us to keep on improving and finding solutions that position us at the cutting edge of the industry. Such as our Remote Service, which we use to resolve operating issues instantly and remotely.

Spare parts in stock

We have the necessary spare parts in stock to provide a fast, immediate service. Therefore our customers can keep on working with the peace of mind that comes from having their equipment performing optimally with verified parts.

Milling head maintenance

We have specialists and state-of-the-art resources to maintain and repair our MTE milling heads. Once the heads have been repaired, they are tested on our test benches before being sent to our customers.

Milling head replacement and rental

To avoid machine downtime as much as possible, we offer a milling head replacement and rental service. We have all the range of MTE milling heads available for if a head is being repaired or there is a one-off need.



MTE MILLING MACHINES

MTE Machine Tool Engineering, S.A. · Polígono Industrial, Parcela M-4, 1 · E-20829 Itziar-Deba (Spain) · Tel.: +34 943 60 63 83 · info@mtemachine.com

www.mtemachine.com

* We reserve the right to carry out technical modifications, which serve to improve the technical development of the machine. For these reasons, all technical data in our advertisements, catalogues etc. are non-obligatory.